



PATENTED SHALLOW-DIP-TECHNOLOGY + CONTACT HEAT
STAY-COOL EDGES

>> MUST READ ALL PAGES !!!

TEPPANYAKI COOK TOP SPECIFICATIONS
Size: Ø 23-5/8" x H 2" (Ø 60 cm x 5 cm H)

~226 square inches **HOT SPOT** max. 4 persons
Total cooking area ~380 sq/in incl. warming
INDOOR + OUTDOOR USE | IPX4 RATED

Material: Professional Food Grade Best Alloy German Stainless Steel type 304 (V2A) 1/8" thick (3 mm) cold pressed, hand-welded. Built-to-last. Silk-brushed hand finish.

Power: **1800 Watt** | 1.8 kWh on high
Electric: **120V | 50-60 Hz | 20 AMP**
ProStyle **2250 Watt | 240V | 10 AMP**

Analog temperature control:
1-10 dial | 2 indicator lights | thermostat
Contact Heat: 130°F to 450°F (55°-230°C)

5 Year Limited Manufacturer Warranty
Material & Workmanship.

Electrical + electronic parts:
1 year limited manufacturers' parts + labor.
VDE issued CE/GS European Safety Approval.
Electrical + Electronic
Components: UL approved.

OPTIONS:

- control box "B" for interior mount (default)
- control box "A" for undermount + outdoors

Ship weight 35 lbs. | ship size 36" x 31" x 7"
Ship weight 16 kg | ship size 93 x 74 x 13 cm

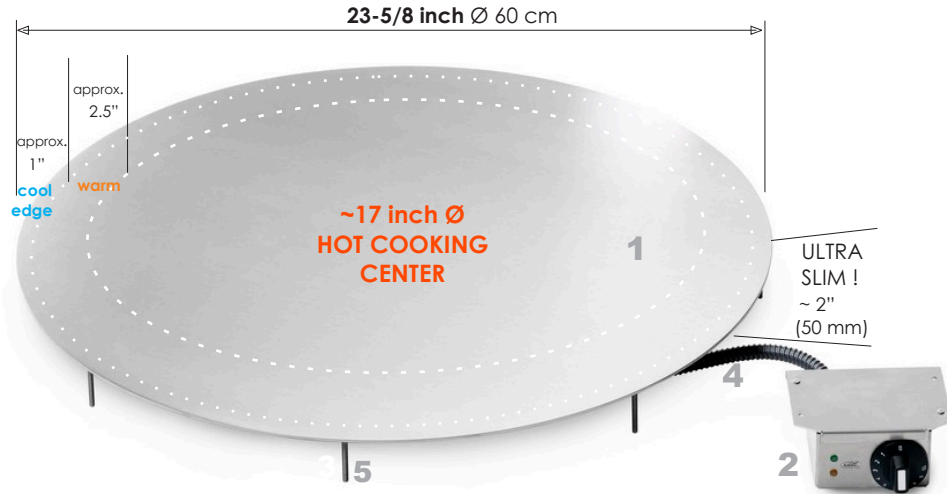

Shown: undermount "A" control



- 1 SOLID STAINLESS STEEL GRILL TOP
- 2 CONTROL BOX "A" for open under mount
- 3 Box "B" plate w/indicator lights + dial knob
- 4 FLEXIBLE CONDUIT
- 5 STAINLESS STEEL MOUNTING BOLTS 1-3/4" stainless steel washers & nuts included

10 ft. (3 m) POWER CORD included



The manufacturer reserves the right to update, change, alter or discontinue any model without further notice.

Shown accessories not included.



Stainless steel production uses 60-80% recycled raw material



Electrical Rating: 120V | 1800 Watt | 20 AMP | 50-60 Hz
 1.8 kWh on high (alt. 240V/1800 Watt, 8 AMP or ProStyle 2250W-240V, 10 AMP)

▶ ALWAYS Check control box label for correct voltage BEFORE plugging in!

Bolts are 1-3/4 inch (45 mm) long; bolt diameter is 13/64"Ø (5 mm) ▶ drill 5/16"Ø (8 mm)

**!!! IMPORTANT: DO NOT DRILL NOR CUT ANY HOLES BEFORE UNIT IS PHYSICALLY PRESENT
 !!! DO NOT CUT OFF THE BOLTS !!! DO NOT OPEN CONTROL BOX OR WARRANTY BECOMES VOID !!!**

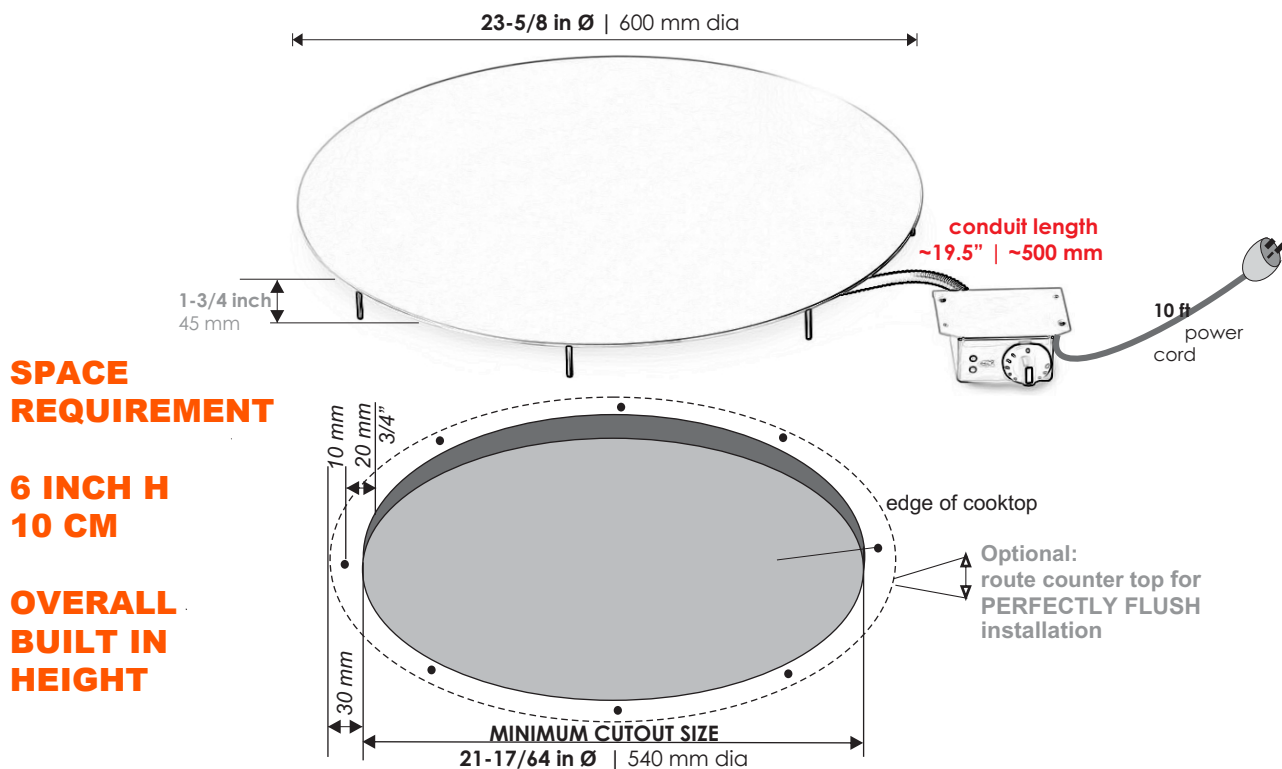

SPACE REQUIREMENT

**6 INCH H
10 CM**

**OVERALL
BUILT IN
HEIGHT**

▶ The Control Box **MUST** be firmly fastened to a **NON-MOVING** surface. Secure power cord and conduit.

▶ **CAUTION: DO NOT SNAP, PULL or TWIST THE CONDUIT DURING INSTALLATION !!!**

Warranty becomes void if capillary tube (thermostat) inside the conduit is damaged during installation.

1. Mark bolt holes, drill 5/16 inch Ø | 8 mm Ø - bolts will fit holes loosely. Clean counter surface thoroughly!!!

2. Clean underside edges of unit with rubbing alcohol or similar.

Apply thin bead of Silicone Sealant around the edges of the underside of the unit. Do not leave any gaps. This protects from potential moisture intrusion, especially when installed outside without overhead cover.

!!! IMPORTANT NOTE: MAKE SURE TO PREVENT SILICONE FROM GETTING INTO THE BOLT HOLES !!!

3. Slide cook top into place. Do not apply excessive force. Unit needs to go in without any resistance.

Press down evenly to compress Silicone. Secure **ALL* BOLTS** with supplied nuts and washers from underneath. Find all nuts, washers and the extension key for "B" control in a small plastic bag inside the pouch.

!!! IMPORTANT: Tighten nuts with hand tool only. Do not use any power tools!!! *otherwise warranty becomes void.

4. Mark, drill and fasten the control box into place ▶ **REFER TO SEPARATE INSTALL SHEET FOR "B" CONTROL**

Optional: seal the round metal plate with Silicone to prevent potential moisture intrusion.

IMPORTANT: Check for correct voltage on unit AND outlet. Now connect the power cord **VERY FIRMLY** to the rear of the control box. Connect the electrical 3-prong plug (other end) to a properly grounded power outlet.

Bolts/studs are 1-3/4 inch (45 mm) long; bolt/stud diameter is 3/16"Ø (5 mm) ▶▶ drill 5/16"Ø (8 mm) !!!

VERY IMPORTANT:

▶▶ **DO NOT CUT OR DRILL BEFORE UNIT IS PHYSICALLY PRESENT. DO NOT CUT OFF THE BOLTS/STUDS** ◀◀

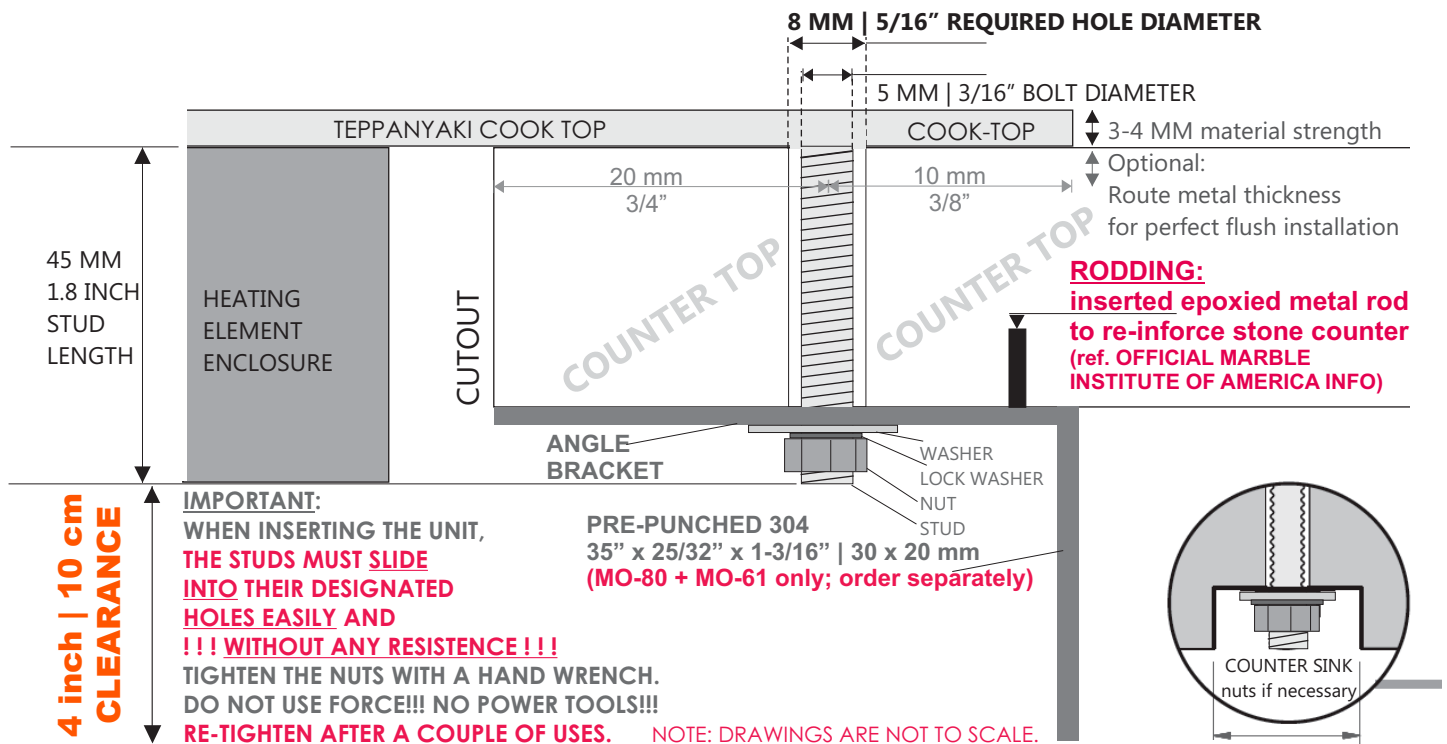

▶▶ **ATTENTION !!! MUST READ !!! INSTALLATION INTO STONE/GRANITE COUNTER TOPS** ◀◀

Please be reminded that the CND stainless steel teppanyaki grill surface will flex slightly when switched on thus developing a shallow dip in the cooking center. This motion is intended and is counteracted by the secured studs, which hold the unit in place. **Talk to your supplier and installer ahead of time. You must provide them with a full set of install sheet documentation at that time.** An experienced stone professional will be able to advise on all aspects to watch out for, e.g. on how much counter-top (“meat”) is necessary at the narrowest point for the particular stone of choice to accommodate a Cook-N-Dine built-in teppanyaki appliance properly.

MO-80: Absolute minimum 6 inches from counter edge to edge of cooking top are strongly advised.

IMPORTANT NOTE: COUNTER TOP THICKNESS OF ~1.5 IN (40 mm) IS MANUFACTURER ADVISED UNLESS MATERIAL HAS BEEN RE-INFORCED BY MEANS OF RODDING OR COMPARABLE.

RODDING is a professional business practice to strengthen porous, fissured or “brittle” Natural Stone/Granite. Narrow areas of material surrounding large cutouts (e.g. sinks, cook tops) are **reinforced on the underside**. This will support and strengthen those areas and is intended to prevent possible damage.

CND offers 304 stainless steel custom-made 12 gauge pre-punched angle brackets (order separately) which can be installed along the full length of the cutout (both long sides). The unit is then fastened through the brackets’ pre-punched holes (see above). Stress applied to the counter material during operation should thus be evenly distributed. **VERY IMPORTANT:** The use of brackets cannot guarantee the prevention of damage. Everything strictly depends on the natural properties of the counter top material. Therefore, Cook-N-Dine cannot be held responsible for any type of damage to stone counter tops due to installation/operation of CND units.

! Make sure to HAVE THE UNIT and ALL install sheets ON SITE ahead of time for counter top templating !

▶▶ **CAUTION: DO NOT SNAP, PULL or TWIST THE FLEXIBLE CONDUIT DURING INSTALLATION !!!**
Warranty becomes void if capillary tube inside the conduit (thermostat) is damaged during installation.
CONTROL BOX MUST BE FIRMLY FASTENED TO A NON-MOVING SURFACE.



▶▶ **CAUTION: DO NOT SNAP, PULL or TWIST THE CONDUIT DURING INSTALLATION !!!**
 Warranty will expire if capillary tube inside the conduit is damaged during installation.
 Control box must be firmly fastened to a non-moving surface.

▶▶ **VERY IMPORTANT: Do not open the control box or warranty expires !!!**

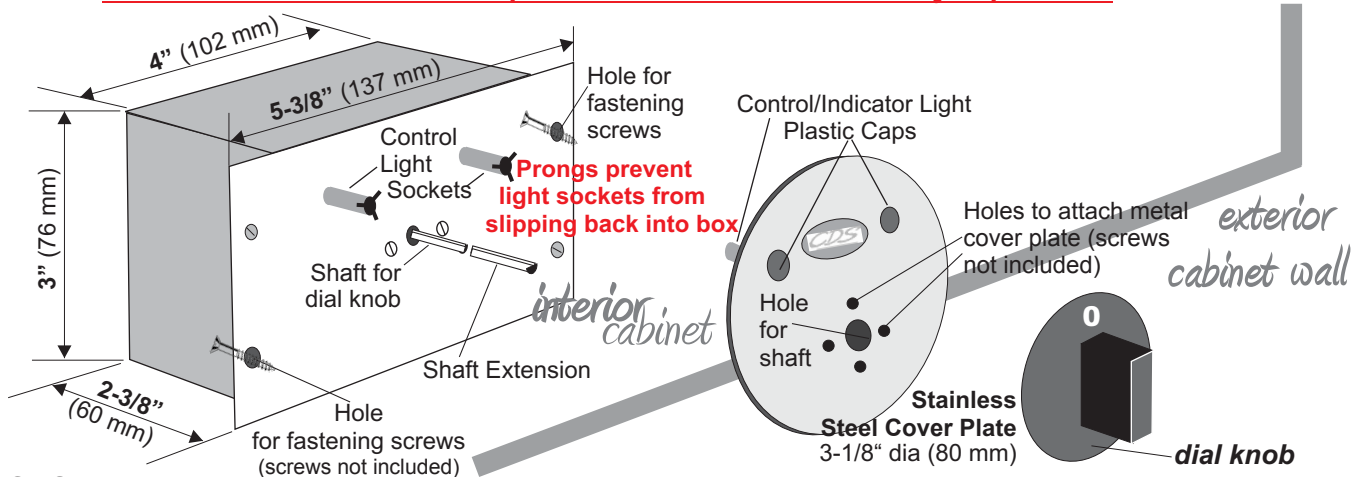

DIRECTIONS:

1. Remove packaging and carefully pull off the DIAL KNOB ONLY while holding on to the round plate. Do not use force or tools!
2. Now separate the round steel plate from Control Light Sockets by carefully wiggling it away WITH the yellow and green light plastic caps. Hold one with two fingers and gently pull plate away; repeat with other. Yellow and green PLASTIC CAPS STAY IN PLACE in the plate.)
3. Mark all necessary holes utilizing the provided template below. Drill required holes and gently thread light sockets through their designated openings. **DO NOT SNAP THE PRONGS!** Now fasten the box to interior of cabinet wall or underside of counter top.
4. Gently pull light sockets out a little bit and re-connect with plastic caps in the metal plate; affix plate with two small flathead screws, or silicone into place. **CAUTION: DO NOT TWIST OR SNAP DELICATE WHITE WIRING OF INDICATOR LIGHTS.**
5. Connect the hollow extension to shaft if needed (packed with nuts + washers). Slide dial knob onto stem (match flat side of stem with flat side of female receptacle at back of knob). Do not use force. The "0" has to align centered below the CDS logo; 12 o'clock

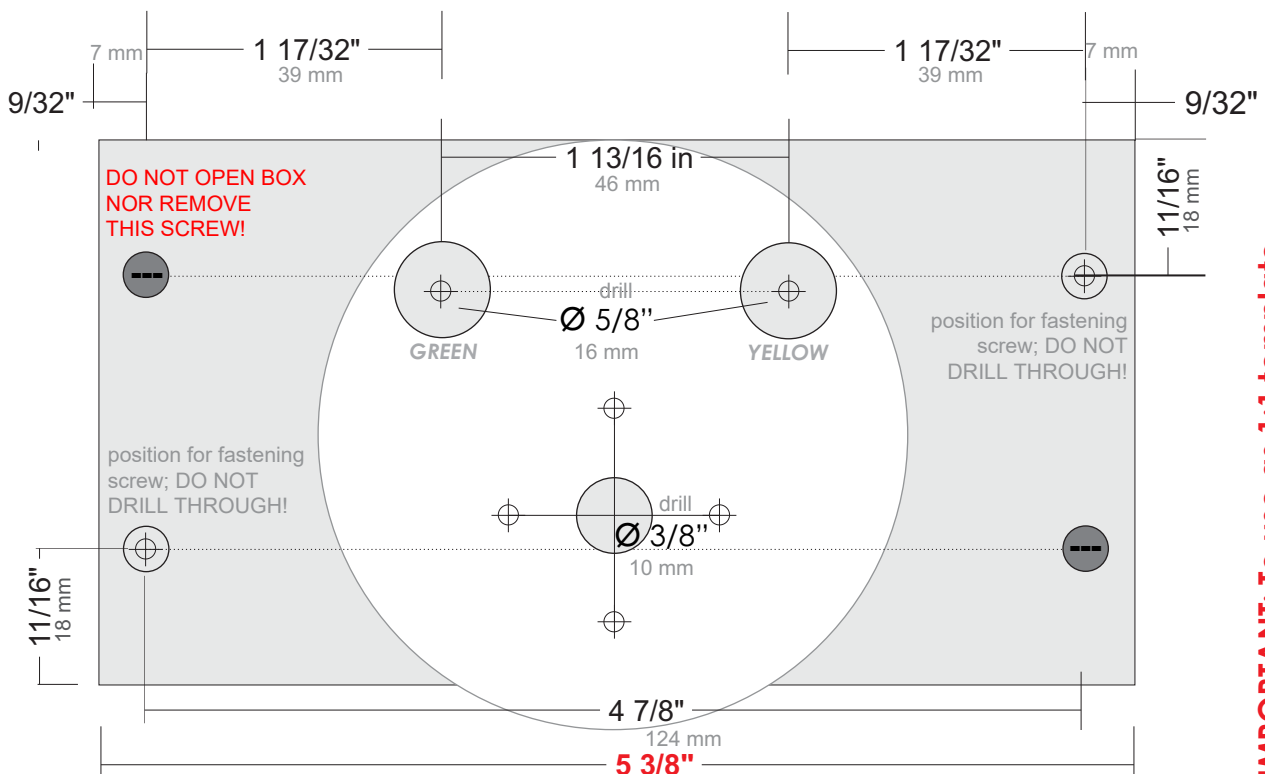

▶▶ 137 mm - PLEASE MEASURE ACROSS TO MAKE SURE TEMPLATE IS 1:1

IMPORTANT: To use as 1:1 template set "page scaling" to "none" when printing