

## 24" SIGNATURE SERIES DUAL-ZONE REFRIGERATOR/WINE RESERVE

**HP24CS-3**      24" INDOOR MODEL  
**HP24CO-3**      24" OUTDOOR MODEL



Glass Door Model



Solid Door Model

### GENERAL SIGNATURE SERIES FEATURES



- **Industry Exclusive** front-vented RAPIDcool forced-air refrigeration system provides best-in-class cooling performance
- Powerful yet efficient 995 BTU variable-speed compressor ramps up to quickly bring down temperature of room temperature product
- **Industry Exclusive** two independently-controlled temperature zones allow you to store wine and beverages together
- Commercial-grade stainless steel interior and exterior
- All models available with stainless steel or panel ready door. Panel ready doors come ready to accept customer-supplied overlay and handle
- **Industry Exclusive** full extension refrigerator and wine shelves provide easy access for stocking and retrieving product. Shelves glide smoothly in and out of cabinet on stainless steel ball bearing glides
- Zero-clearance hinging allows for abutment with surrounding cabinetry
- Adjustable Crisp White and Cool Blue LED lighting
- Low E, double pane UV-resistant glass provides exceptional insulation and protection from light
- State-of-the-art digital control module
- Comprehensive Full Three Year Warranty plus additional three years on sealed system

### HP24CS/CO FEATURES

- Available with stainless steel solid door, panel ready solid door, stainless steel glass door or panel ready glass door
- Includes two (2) full-extension wine shelves and one (1) full-extension refrigerator shelf
- Wine shelves feature stainless steel fronts
- Product capacity is 14 wine bottles and 41 cans (12 oz.)
- Wine Reserve (top zone) temperature 45°- 65°F
- Refrigerator (lower zone) temperature 33°- 42°F

### ACCESSORIES

(L)	Factory Installed Lock
67991-L/R	Stacking Kit for HP24/HC24/HA24 models
66736	Caster Kit for HP24/HC24/HA24 models
RS-24-24D	Divider Shelf for HP24/HC24/HA24 models

Perlick accessories are available for purchase through an authorized Perlick dealer. For a full list of accessories and to find a dealer near you, visit [perlick.com/residential](http://perlick.com/residential)

## PRODUCT SPECIFICATIONS

Product Width	23-7/8" (606 mm.)
Product Height	34-1/4" (870 mm.)
Product Depth	24" (610 mm.)
Opening Width	24" (610 mm.)
Opening Height	34-1/2" (876 mm.)
Opening Depth**	24-7/8" (632 mm.)
Refrigerated Volume	5.0 cu. ft.
Door Swing Clearance	25" (635 mm.) minimum
Electrical	115V, 60Hz., 1 Phase, 2.3 amps
Compressor	995 BTU, variable-speed
Plumbing	None Required
Annual Energy Usage	295 kWh/yr
Shipping Weight	203 lbs (92.08 kg.)

\*\* Includes 7/8" plug clearance. To achieve 24" depth, you must recess the plug into the wall directly behind the unit.

## INDOOR MODELS

HP24CS-3-1L*	Stainless steel solid door, hinge left
HP24CS-3-2L*†	Panel ready solid door, hinge left
HP24CS-3-3L*	Stainless steel glass door, hinge left
HP24CS-3-4L*†	Panel ready glass door, hinge left

## OUTDOOR MODELS

HP24CO-3-1L*	Stainless steel solid door, hinge left
HP24CO-3-2L*†	Panel ready solid door, hinge left
HP24CO-3-3L*	Stainless steel glass door, hinge left
HP24CO-3-4L*†	Panel ready glass door, hinge left

\* Also available hinge right (R)

† This unit comes ready to accept customer-provided overlay panel and handle

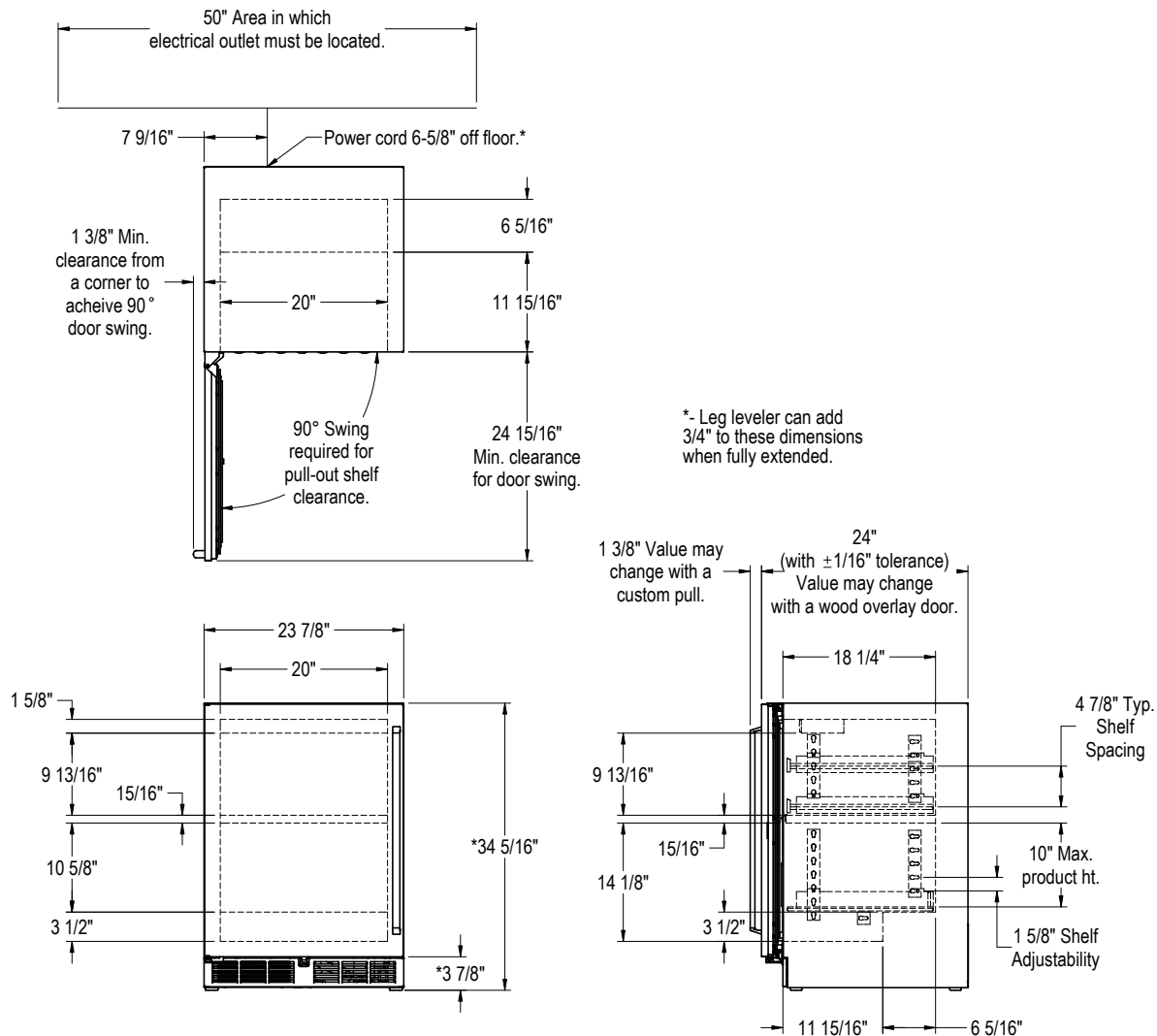

\* - Leg leveler can add 3/4" to these dimensions when fully extended.

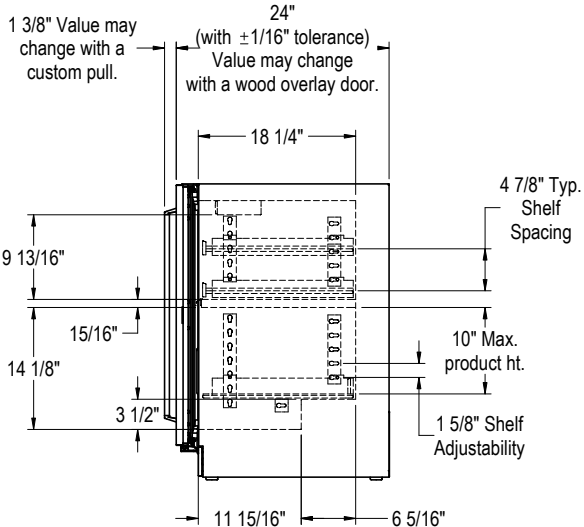

California Prop 65 Notice:

**WARNING:** The materials used in this product may contain chemicals known to the State of California to cause cancer and birth defects or other reproductive harm. For more information go to [www.P65Warnings.ca.gov](http://www.P65Warnings.ca.gov).

FORM NO. Z2541  
REV. A-09/07/2018