

EN Installation, Operation and maintenance Instructions
FR Instructions d'installation, d'utilisation et d'entretien
ES Instrucciones de instalación, operación y mantenimiento

Outdoor Beer Dispensers
Distributeurs de bière extérieur
Dispensadores de cerveza exterior

MO24BN
MO24BS
MO24BT



CONTENTS

Contents:

Safety information	2
Unpacking your appliance	3
Warranty registration	3
Installing your appliance	4
Cabinet clearances	4
Leveling the appliance	4
Electrical connection	5
Installing the anti-tip device	6
Product dimensions MO24BN	8
Product dimensions MO24BS and MO24BT	9
Product dimensions MO24BSSM and MO24BTSM	10
Using your Electronic control	11
Starting your appliance	11
Turning your appliance "ON" or "OFF"	11
Adjusting the temperature	11
Beer dispenser operation	11
Alarms	11
Door ajar	11
Temperature sensor fault	11
Alarm mute ..	11
Using your beer dispenser.....	12
Shelving	12
Tap equipment and assembly.....	13
Externally mounting CO ₂ tank	17
CO ₂ regulator	18
Drain kit	19
Care and cleaning	19
Cleaning the drain sump	19
Keg coupler cleaning	20
Faucet cleaning	20
Tap cleaning kit	21
Cleaning the beer line	21
Front grille	21
Cabinet	21
Interior	21
Long term storage / winterization	22
Stainless steel maintenance	24
Door alignment	25
Energy saving tips	25
Troubleshooting	26
Obtaining service	26
Warranty	27

Important Safety Instructions

Warnings and safety instructions appearing in this guide are not meant to cover all possible conditions and situations that may occur. Common sense, caution, and care must be exercised when installing, maintaining, or operating this appliance.

Recognize Safety Symbols, Words, and Labels.



WARNING

WARNING - You can be killed or seriously injured if you do not follow these instructions.



CAUTION

CAUTION-Hazards or unsafe practices which could result in personal injury or property / product damage.

NOTE

NOTE-Important information to help assure a problem free installation and operation.

State of California Proposition 65 Warnings:

WARNING: This product contains one or more chemicals known to the State of California to cause cancer.

WARNING: This product contains one or more chemicals known to the State of California to cause birth defects or other reproductive harm..

AGA MARVEL is committed to building a quality product in an environmentally friendly manner. Our processes are tightly controlled and closely monitored. We have achieved certifications in ISO 9001 for quality assurance, ISO 14001 for environmental management, and OHSAS 18001 for occupational health and safety from Lloyd's Register Quality Assurance.



UNPACKING YOUR APPLIANCE



WARNING

EXCESSIVE WEIGHT HAZARD

Use two or more people to move product.
Failure to do so can result in personal injury.

Remove Interior Packaging

Your appliance has been packed for shipment with all parts that could be damaged by movement securely fastened. Remove internal packing materials and any tape holding internal components in place. The owners manual is shipped inside the product in a plastic bag along with the warranty registration card, and other accessory items.

Important

Keep your carton and packaging until your appliance has been thoroughly inspected and found to be in good condition. If there is damage, the packaging will be needed as proof of damage in transit. Afterwards please dispose of all items responsibly.



CAUTION

Dispose of the plastic bags which can be a suffocation hazard.

Note to Customer

This merchandise was carefully packed and thoroughly inspected before leaving our plant. Responsibility for its safe delivery was assumed by the retailer upon acceptance of the shipment. Claims for loss or damage sustained in transit must be made to the retailer.

NOTE

DO NOT RETURN DAMAGED MERCHANDISE TO THE MANUFACTURER - FILE THE CLAIM WITH THE RETAILER.



CAUTION

If the appliance was shipped, handled, or stored in other than an upright position for any period of time, allow the appliance to sit upright for a period of at least 24 hours before plugging in. This will assure oil returns to the compressor. Plugging the appliance in immediately may cause damage to internal parts.

Warranty Registration

It is important you send in your warranty registration card immediately after taking delivery of your appliance or you can register online at www.agamarvel.com.

The following information will be required when registering your appliance.

Service Number

Serial Number

Date of Purchase

Dealer's name and address

Online registration
available at
www.agamarvel.com

The service number and serial number can be found on the serial plate which is located inside the cabinet on the left side near the top. (See figure 1).

AGA MARVEL	
GREENVILLE, MI 48838	
MODEL NO.	<input type="text"/>
SERVICE NO.	<input type="text" value="XXXXXXXXXX"/>
SERIAL NO.	<input type="text" value="XXXXXXXXXX"/>
HZ <input type="text"/>	VOLTS <input type="text"/> AMPS <input type="text"/> R134A <input type="text"/> oz
TEST PRESSURE 140 PSI LOW SIDE 300 PSI HIGH SIDE	

Figure 1



CAUTION

Help Prevent Tragedies

Child entrapment and suffocation are not problems of the past. Junked or abandoned refrigerators are still dangerous - even if they sit out for "just a few hours".

If you are getting rid of your old refrigerator, please follow the instructions below to help prevent accidents.

Before you throw away your old refrigerator or freezer:

- Take off the doors or remove the drawers.
- Leave the shelves in place so children may not easily climb inside.

INSTALLING YOUR APPLIANCE

Select Location

The proper location will ensure peak performance of your appliance. We recommend a location where the unit will be out of direct sunlight and away from heat sources. To ensure your product performs to specifications, the recommended installation location temperature range is from 55 to 115°F (13 to 46°C).

Cabinet Clearance

Ventilation is required from the bottom front of the appliance. Keep this area open and clear of any obstructions. Adjacent cabinets and counter top can be installed around the appliance as long as the front grille remains unobstructed.

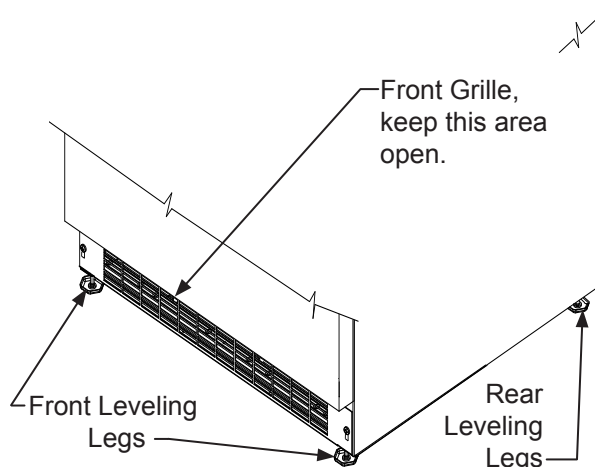

Figure 2

Leveling Legs

Adjustable legs at the front and rear corners of the appliance should be set so the unit is firmly positioned on the floor and level from side to side and front to back. The overall height of your Marvel appliance may be adjusted between the minimum, 33 $\frac{3}{4}$ " (85.7 cm), by turning the leveling leg in (CW ↻) and the maximum, 34 $\frac{3}{4}$ " (88.3 cm) by turning the leveling leg out (CCW ↻).

To adjust the leveling legs, place the appliance on a solid surface and protect the floor beneath the legs to avoid scratching the floor. With the assistance of another person, lean the appliance back to access the front leveling legs. Raise or lower the legs to the required dimension by turning the legs. Repeat this process for the rear by tilting the appliance forward using caution. On a level surface check the appliance for levelness and adjust accordingly.

The front grille screws may be loosened and the grille adjusted to the desired height. When adjustment is complete tighten the two front grille screws. (See Figure 5).



CAUTION

Front Grille

Do not obstruct the front grille. The openings within the front grille allow air to flow through the condenser heat exchanger. Restrictions to this air flow will result in increased energy usage and loss of cooling capacity. For this reason it is important this area not be obstructed and the grille openings kept clean. AGA MARVEL does not recommend the use of a custom made grille as air flow may be restricted. (See Figure 2).

INSTALLING YOUR APPLIANCE

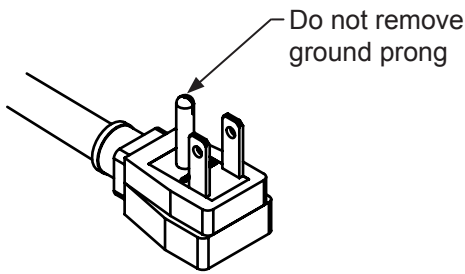

Figure 3

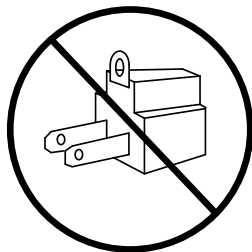

Figure 4

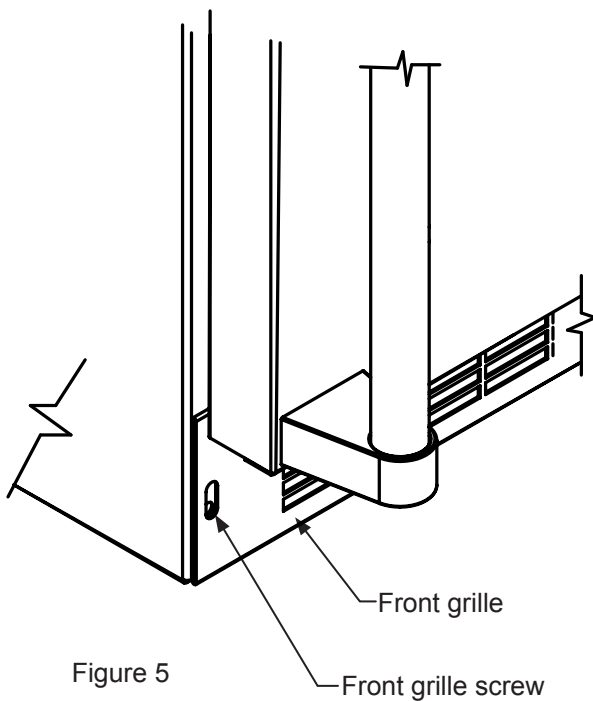

Figure 5



WARNING

Electrical Shock Hazard

- Do not use an extension cord with this appliance. They can be hazardous and can degrade product performance.
- This appliance should not, under any circumstances, be installed to an un-grounded electrical supply.
- Do not remove the grounding prong from the power cord. (See Figure 3).
- Do not use an adapter. (See Figure 4).
- Do not splash or spray water from a hose on the appliance. Doing so may cause an electrical shock, which may result in severe injury or death.

Electrical Connection

A grounded 115 volt, 15 amp dedicated circuit is required.

This product is factory equipped with a power supply cord that has a three-pronged, grounded plug. It must be plugged into a mating grounding type receptacle in accordance with the National Electrical Code and applicable local codes and ordinances (see Figure 6). If the circuit does not have a grounding type receptacle, it is the responsibility and obligation of the customer to provide the proper power supply. The third ground prong should not, under any circumstances, be cut or removed.

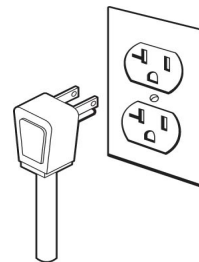

Figure 6

NOTE

Ground Fault Circuit Interrupters (GFCI) are prone to nuisance tripping which will cause the appliance to shut down. GFCI's are generally not used on circuits with power equipment that must run unattended for long periods of time, unless required to meet local building codes and ordinances.

INSTALLING THE ANTI TIP DEVICE FOR FREESTANDING INSTALLATIONS

! WARNING



- ALL APPLIANCES CAN TIP RESULTING IN INJURY.



- INSTALL THE ANTI-TIP BRACKET PACKED WITH THE APPLIANCE.
- FOLLOW THE INSTRUCTIONS BELOW

! WARNING

If your refrigerator is not located under a counter top (free standing), you must use an anti-tip device installed as per these instructions. If the refrigerator is removed from its location for any reason, make sure that the device is properly engaged with the anti-tip bracket when you push the refrigerator back into the original location. If the device is not properly engaged, there is a risk of the refrigerator tipping over, with the potential for property damage or personal injury.

NOTE

If installing on a concrete floor, concrete fasteners are required, (not included with the anti-tip kit).

! CAUTION

Any finished flooring should be protected with appropriate material to avoid damage when moving the unit.

Floor Mount Installation

The anti-tip bracket is to be located on the floor in the left or right rear corner of the beer dispenser as shown in Figure 7.

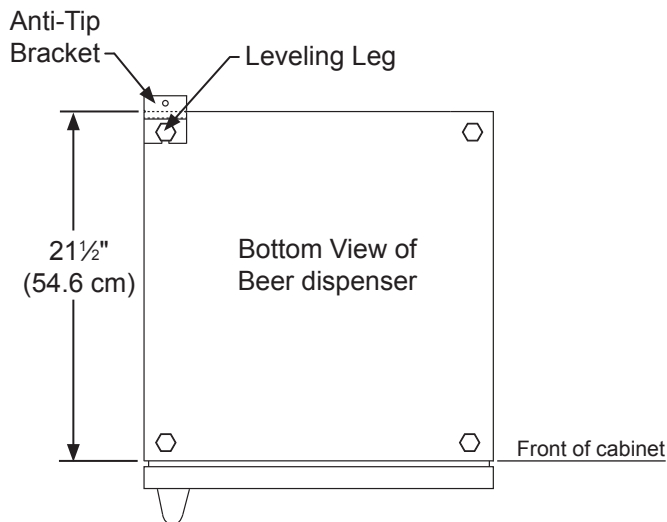

Figure 7

Step by step instructions for locating the position of the bracket:

- 1) Decide where you want to place the beer dispenser. Slide it into place, being careful not to damage the floor, leaving 1" (2.5 cm) of clearance from the rear wall to allow room for the anti-tip bracket.
- 2) Raise the rear leveling legs approximately 1/4" (6 mm) to allow engagement with the anti-tip bracket. Level the unit by adjusting all the leveling legs as required. Turning the leveling leg counterclockwise will raise the unit and clockwise will lower the unit.
- 3) Make sure the beer dispenser is in the desired location, then mark on the floor the rear and side corner of the cabinet where the anti-tip bracket will be installed. If the installation does not allow marking the rear corner of the cabinet, then make temporary lines on the floor marking the front corner of the cabinet, excluding the door. Slide the beer dispenser out of the way. From the temporary line extend the sidewall line back 21 1/2" (54.6 cm) as shown in Figure 8.
- 4) Align the anti-tip bracket to the marks on the floor so the side of the bracket lines up with the side of the cabinet mark, and the "V" notches on the anti-tip bracket line up with the end of the 21 1/2" (54.6 cm) line (Rear of cabinet line).
- 5) Fasten the anti-tip bracket to the floor using the supplied screw. (See Figure 8).
- 6) Slide the cabinet back into position, making sure the rear cabinet leveling leg slides under the anti-tip bracket engaging the slot.

INSTALLING THE ANTI TIP DEVICE FOR FREESTANDING INSTALLATIONS

NOTE

When the floor mounted anti-tip bracket is used the minimum adjusted height of the cabinet is increased by $\frac{3}{8}$ " (9 mm).

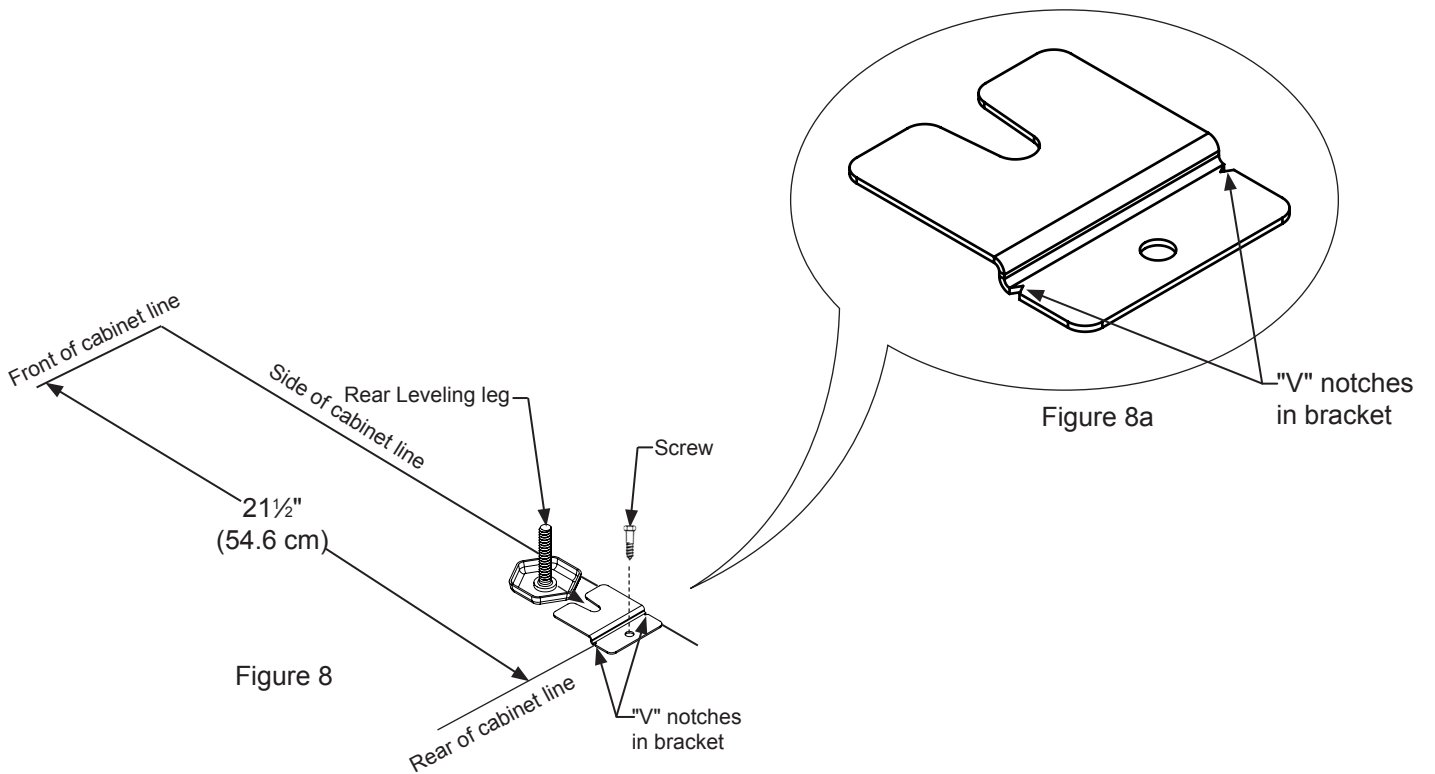

PRODUCT DIMENSIONS MO24BN

MODEL	ROUGH-IN OPENING DIMENSIONS			CABINET DIMENSIONS					
	"A"	"B"	"C"	"D"	"E"	"F"	"G"	"H"	"J"
MO24BNS	24" (61 cm)	**34" to 35" (86.4 to 88.9 cm)	*	23 ⁷ / ₈ " (60.7 cm)	33 ³ / ₄ " to 34 ³ / ₄ " (85.7 to 88.3 cm)	23 ²³ / ₃₂ " (60.2 cm)	26 ¹ / ₄ " (66.7 cm)	46 ¹³ / ₃₂ " (117.9 cm)	26 ¹ / ₄ " (66.7 cm)

PRODUCT DATA		
MODEL	ELECTRICAL REQUIREMENTS#	PRODUCT WEIGHT
MO24BNS	115V/60Hz/15A	140 lbs (63.6 kg)

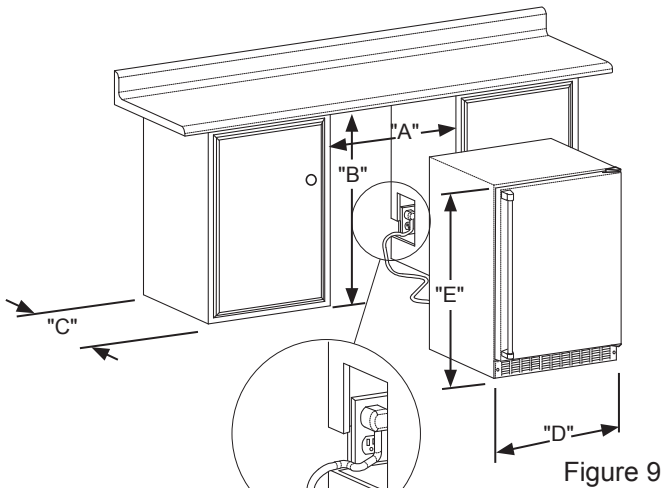

Figure 9a

If necessary to gain clearance inside the rough-in opening a hole can be cut through the adjacent cabinet and the power cord routed through this hole to a power outlet. Another way to increase the available opening depth is to recess the power outlet into the rear wall to gain the thickness of the power cord plug. Not all recessed outlet boxes will work for this application as they are too narrow, but a recessed outlet box equivalent to Arlington #DVFR1W is recommended for this application, (see Figure 11).

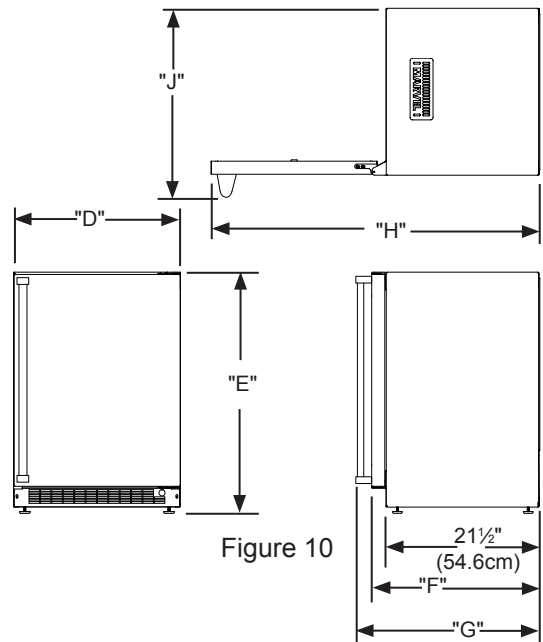

Figure 10



Figure 11

* Depth dimension of rough-in opening may vary depending on each individual installation. To recess entire door "F" dimension plus 1" (2.5 cm) for thickness of power cord plug is required.

** Minimum rough-in opening required is to be larger than the adjusted height of the cabinet.

A grounded 15 amp dedicated circuit is required. Follow all local building codes when installing electrical and appliance.

PRODUCT DIMENSIONS MO24BS AND MO24BT

MODEL	ROUGH-IN OPENING DIMENSIONS			CABINET DIMENSIONS					
	"A"	"B"	"C"	"D"	"E"	"F"	"G"	"H"	"J"
MO24BS(S) MO24BT(S)	24" (61 cm)	**34" to 35" (86.4 to 88.9 cm)	*	23 ⁷ / ₁₆ " (60.7 cm)	33 ³ / ₄ " to 34 ³ / ₄ " (85.7 to 88.3 cm)	23 ²³ / ₃₂ " (60.2 cm)	26 ¹ / ₄ " (66.7 cm)	46 ¹³ / ₃₂ " (117.9 cm)	26 ¹ / ₄ " (66.7 cm)

PRODUCT DATA		
MODEL	ELECTRICAL REQUIREMENTS#	PRODUCT WEIGHT
MO24BS(S) MO24BT(S)	115V/60Hz/15A	140 lbs (63.6 kg)

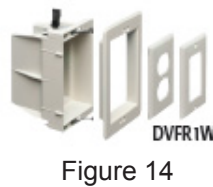
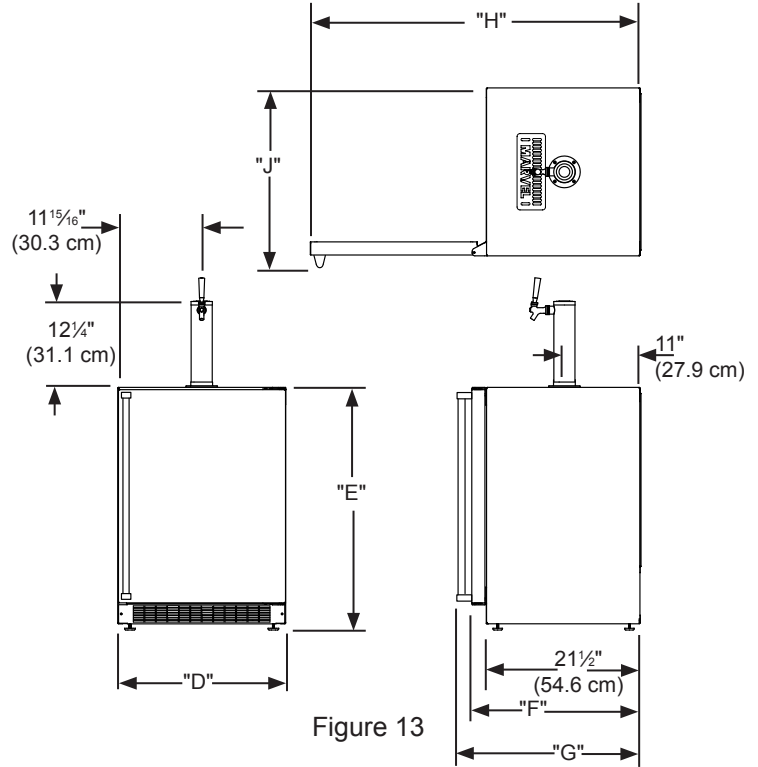
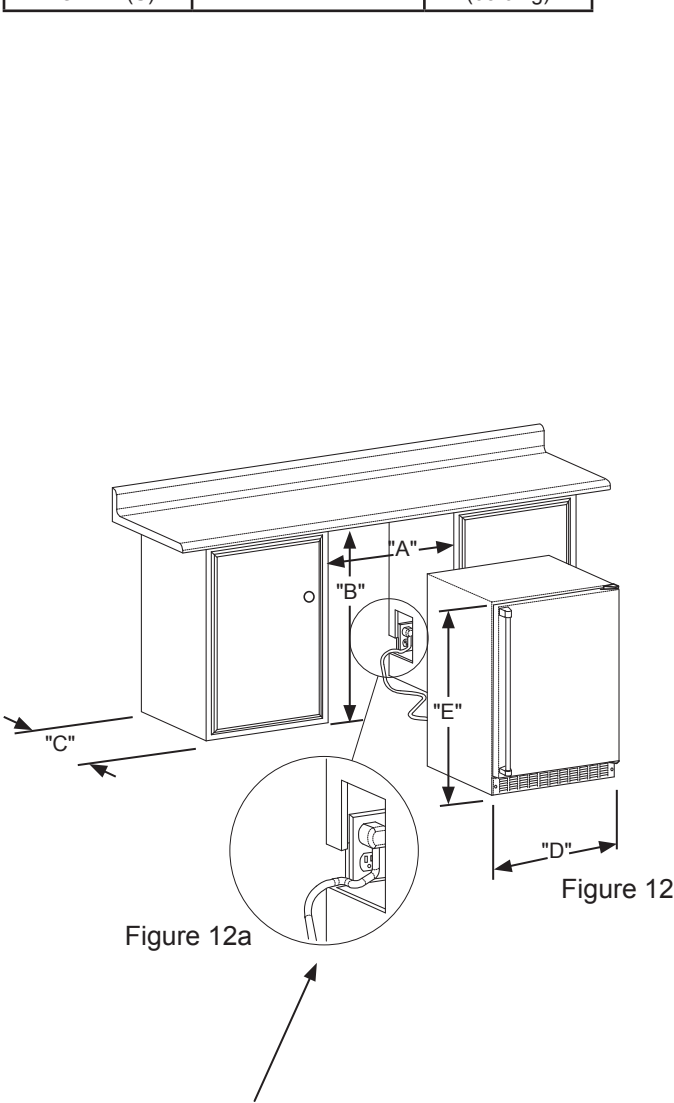

If necessary to gain clearance inside the rough-in opening a hole can be cut through the adjacent cabinet and the power cord routed through this hole to a power outlet. Another way to increase the available opening depth is to recess the power outlet into the rear wall to gain the thickness of the power cord plug. Not all recessed outlet boxes will work for this application as they are too narrow, but a recessed outlet box equivalent to Arlington #DVFR1W is recommended for this application, (see Figure 14).

* Depth dimension of rough-in opening may vary depending on each individual installation. To recess entire door "F" dimension plus 1" (2.5 cm) for thickness of power cord plug is required.

** Minimum rough-in opening required is to be larger than the adjusted height of the cabinet.

A grounded 15 amp dedicated circuit is required. Follow all local building codes when installing electrical and appliance.

PRODUCT DIMENSIONS MO24BSSM AND MO24BTSM

Single dispense tower shown

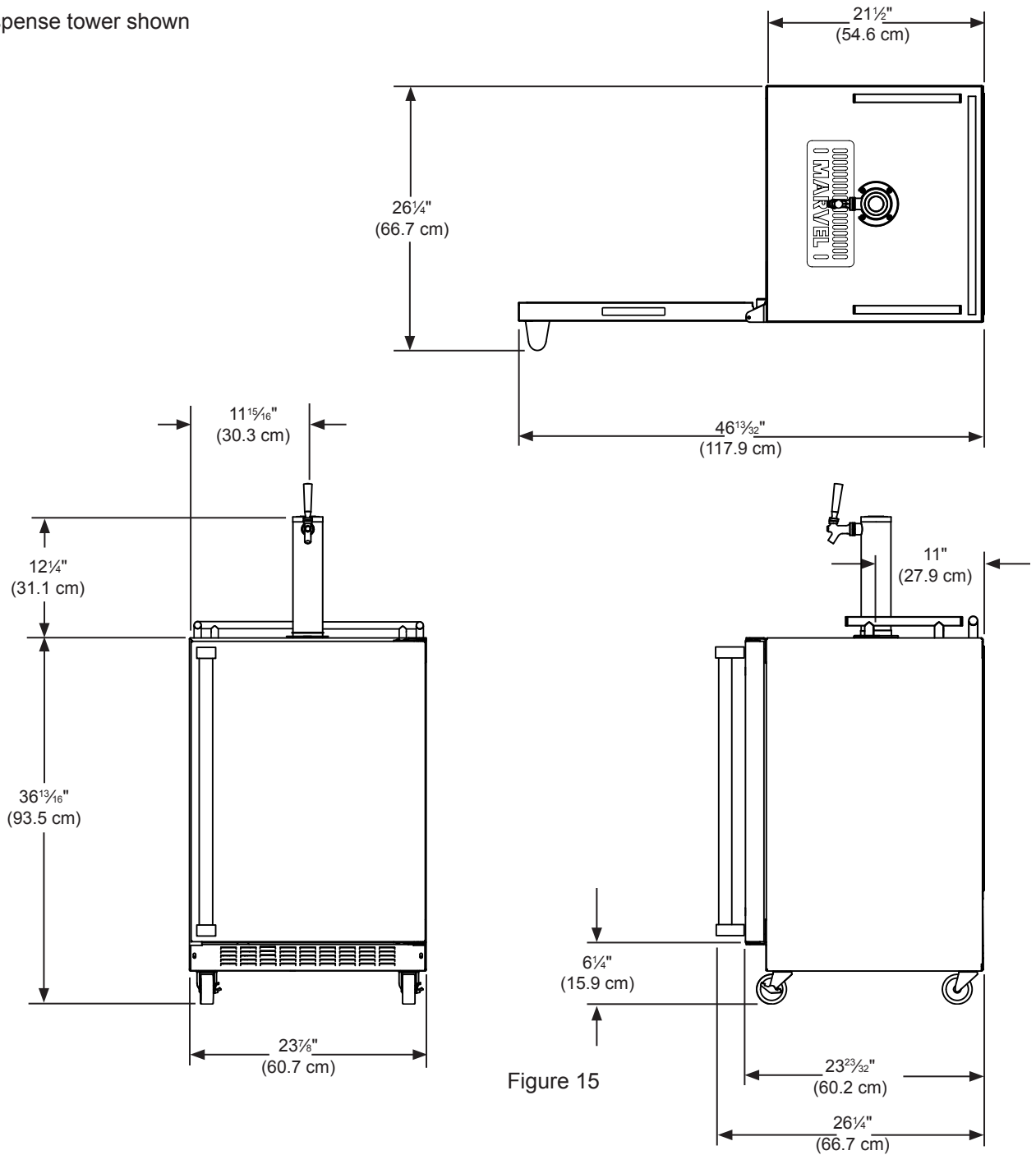

Electrical Requirements: A grounded 115 volt, 15 amp dedicated circuit is required.

Power outlet can be located in the back wall behind unit. Follow all local building codes when installing electrical and unit. Product weight = 150 lbs. (68.2 kg.)

USING YOUR ELECTRONIC CONTROL

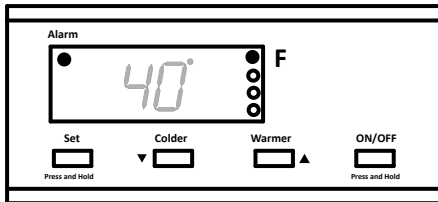

Figure 16
close-up of
control

Starting your beer dispenser

Plug the beer dispenser power cord into a wall outlet. Your beer dispenser will begin cooling after power is applied. If your beer dispenser does not start, check that the beer dispenser is turned on and the set temperature is cold enough.

Turning your beer dispenser ON or OFF

If the beer dispenser is on, the beer dispenser temperature will be shown on the display. To turn the beer dispenser off, press and hold the "ON/OFF" button for three (3) seconds. "OFF" will appear on the display.

If the beer dispenser is not on, "OFF" will be shown on the display. To turn the beer dispenser on, press and hold the "ON/OFF" button for three (3) seconds. The beer dispenser temperature will be shown on the display.

Set temperature

To set the beer dispenser temperature, press and hold the "SET" button. When the "SET" button is pressed, the display will show the set temperature. While holding the "SET" button, press the "WARMER" or "COLDER" buttons to adjust set temperature.

Beer dispenser operation

The available temperature range of the beer dispenser is 34° to 46°F (1° to 8° C).

It may take up to 24 hours for your beer dispenser to reach desired temperature. This will depend on amount of content loaded and number of door opening and closings.

For best results allow beer dispenser to "pull down" to desired set temperature before loading. Once contents are loaded, allow at least 48 hours for temperature to stabilize before making any adjustments to the set temperature.

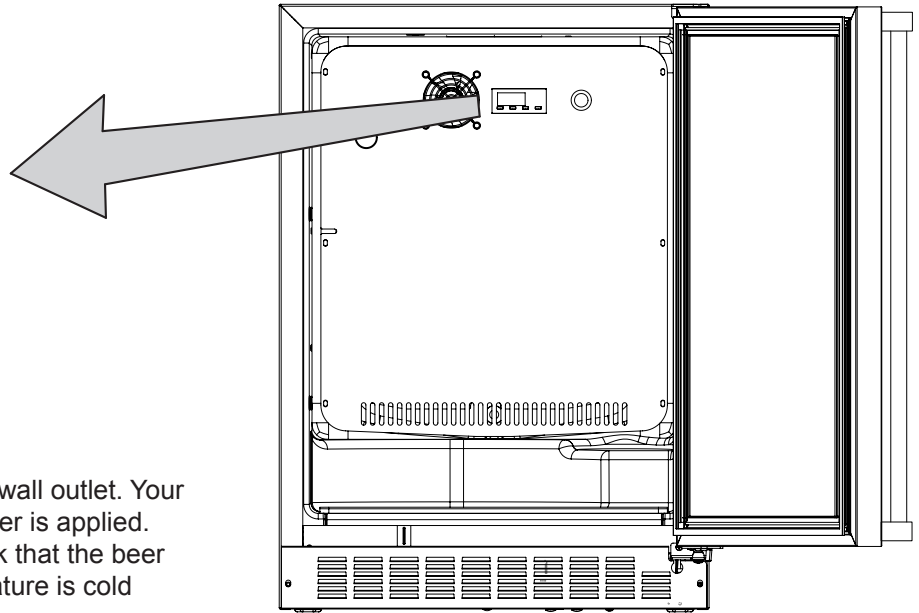

Figure 17

Alarms

Your MARVEL Prime Controls™ will monitor beer dispenser function and alert you with a series of audible and visual alarms.



- **Door Ajar Alarm:** If the door has been left open for over five (5) minutes, the alarm will sound in one (1) second intervals. The display panel will flash "do" and the Alarm LED located at the top left of the display below the word "Alarm" will be illuminated. This will stop as soon as the door is closed.



- **Temperature Sensor Fault:** If the controller detects that the temperature sensor is not properly functioning, a temperature sensor alarm will sound in one (1) second intervals. "E1" will flash on the display panel and the Alarm LED located at the top left of the display below the word "Alarm" will be illuminated. Please call AGA MARVEL Customer Service or your dealer if this error code is displayed.

Alarm Mute

Press any key to mute the audible portion of an alarm. NOTE-This action will only mute the alarm. If the condition that caused the alarm continues, the alarm code will continue to flash and will sound for 20 seconds every 60 minutes.

USING YOUR BEER DISPENSER

Shelving

The unit is shipped with the (2) shelves taped in place in the upper and the lower shelf positions. Remove them from the refrigerator and arrange them as follows when setting up your unit.

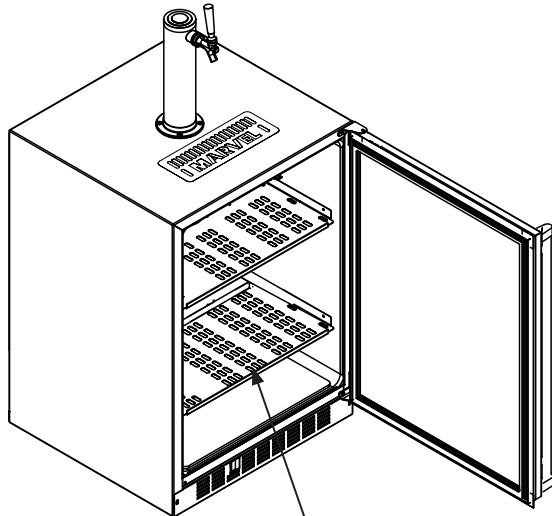

Figure 18 Two shelves

If you are not serving beer on tap, your keg dispenser can be used as a refrigerator by placing both shelves on the mounting brackets as shown in Figure 19. The shelves are marked upper and lower. The upper shelf should be placed in the top shelf position and the shelf marked lower should be placed in the bottom shelf position.

CAUTION

If you are using the appliance as a refrigerator for perishable foods, the set-point temperature should be set between 34°F and 42°F (1.2°C and 5.7°C).

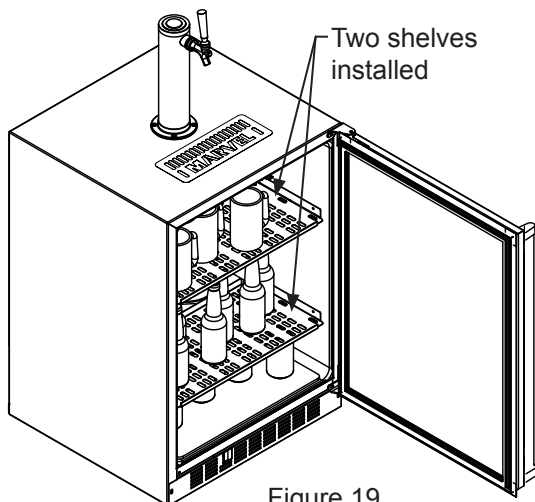
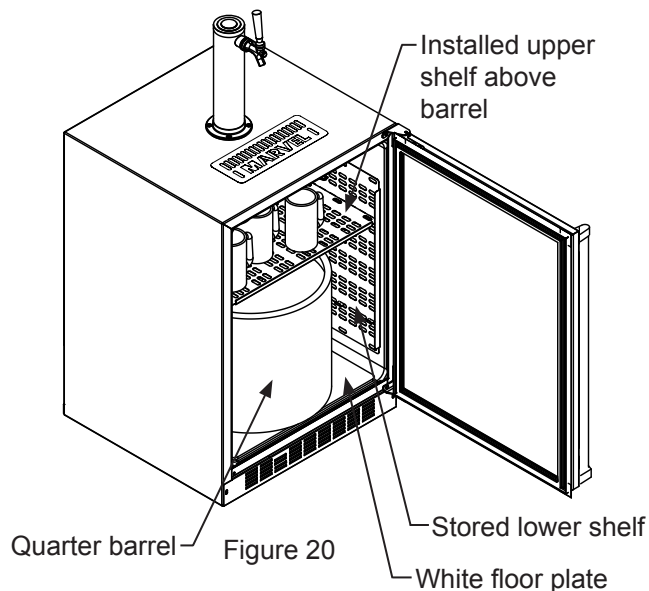

Figure 19

If you are using a quarter barrel of beer, you can add shelf space for keeping your mugs chilled. The quarter barrel must set on the floor, it cannot fit on the shelf, see Figure 20. Be sure the white floor plate is in the bottom of the interior compartment before positioning the barrel.



Quarter barrel Figure 20

If you are using a half barrel (keg) or (2) 1/6 barrels, place the two shelves on the right side of the keg dispenser on the two mounting hooks for storage. (See Figure 21). Be sure the white floor plate is in the bottom of the interior compartment before positioning the barrel(s).

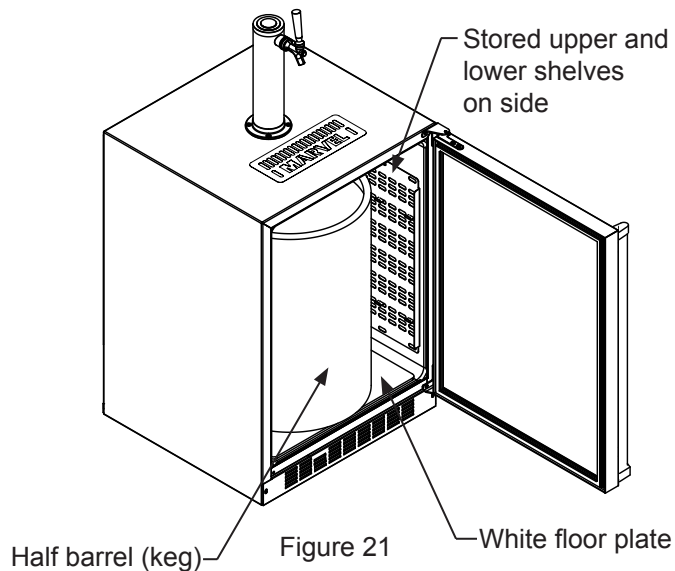

Half barrel (keg) Figure 21

USING YOUR BEER DISPENSER

This beer dispensing unit will support one half (½) barrel or one quarter (¼) barrel. The double draft tower units can support two sixth (⅙) barrels of beer. See chart below for quantity of beer in each barrel size.

	Barrel Sizes		
	1/6 barrel	1/4 Barrel	1/2 Barrel
Height	23 ⁵ / ₁₆ " (59.2 cm)	14 ¹³ / ₁₆ " (37.6 cm)	23 ⁵ / ₁₆ " (59.2 cm)
Diameter	9 ¹ / ₄ " (23.5 cm)	17" (43.2 cm)	17" to 17 ¹ / ₄ " (43.2 to 43 cm)
Gallons	5.16	7.75	15.5
#12 ounce Glasses	60	82	163

Table A

Keg Size	#of kegs per 5 pound CO ₂ Tank
5 gallon Corny	15 to 22
1/6 barrel	14 to 21
1/4 Barrel	10 to 14
1/2 Barrel	5 to 7

Table B

CAUTION

Information that follows on pages 13 through 20 does not apply to models MO24BN, as these models do not include any tap and tower equipment. Refer to your beer equipment manufacturer information regarding to the installation of this equipment.

Tap Equipment and Assembly

Your dispensing kit includes the following parts:

- Polished stainless steel tower with clear beer line (single or double dispense)
- Tower Gasket
- Phillips oval head screws
- Knob for Tower (Faucet Handle)
- Keg coupler(s)
- CO₂ regulator with red gas line(s) attached
- Empty 5 pound CO₂ tank
- Plastic clamp(s) large and small
- Faucet wrench

Tools required for installation:

- Flat bladed screwdriver
- Phillips screwdriver
- Pliers
- Adjustable wrench or a 1½" open end wrench
- ½" open end wrench



WARNING

CO₂ can be dangerous. If it becomes difficult to breathe and/or your head starts to ache, a high concentration of carbon dioxide may be present. Leave the area immediately.

- The CO₂ tank must always be connected to the regulator. **Never** connect the tank to the keg.
- The CO₂ tank must be securely mounted in the upright position. Secure it with the chain provided.
- **Never** drop or throw the CO₂ tank.
- Keep the CO₂ tank away from heat.
- Ventilate the area after a CO₂ leak.

1. Remove shelving and packaged components from the interior of the refrigerator before beginning the assembly process.
2. Take your empty 5 pound CO₂ tank to your local gas supply dealer to be filled. You can usually find them in your "yellow pages" under "Welding Supply" or "Fire Protection". One 5 pound tank can process many kegs (see table "B") Your dealer should supply you with a new plastic washer every time the tank is filled. This washer is used at the regulator to tank connection. See Figure 25 and 32 on page 14. Replace the old washer with the new one whenever the tank is refilled.
3. Tower mounting (if you are installing the unit under a counter skip to step 4). If you are mounting the tower directly to the top of the refrigerator, first remove the four screws from the top of the refrigerator. Feed the clear beer line through the tower gasket and the large hole in the refrigerator top. Align the 4 holes in the tower with the 4 holes in the refrigerator top and secure the tower with the 4 screws removed previously. Skip to step 5.

USING YOUR BEER DISPENSER

Single Dispense Tower Kit

Connect **A** to **A**, etc.....



Single Dispense Tower
Figure 22

Figure 23



Hose clamps use for connections

A and **C**

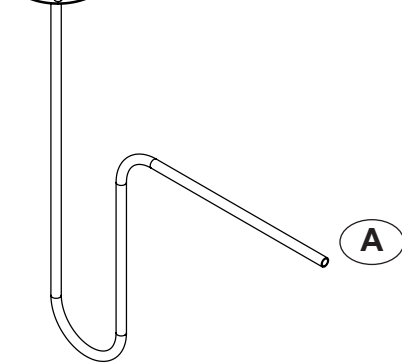

A Figure 24
Keg Coupler

C

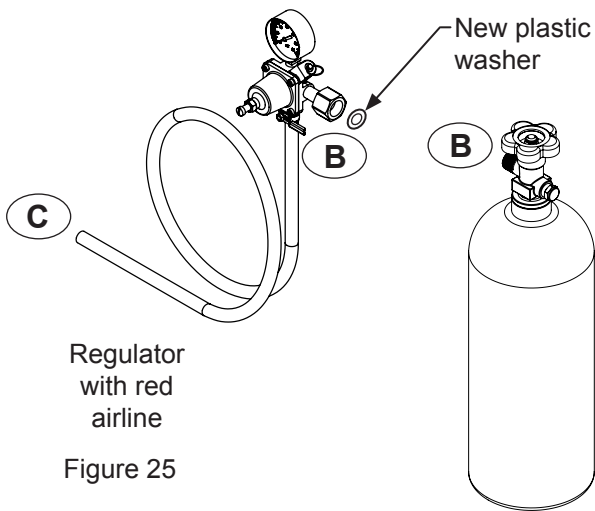

Regulator with red airline

Figure 25

5 Pound CO₂ Tank
Figure 26

Double Dispense Tower Kit

Connect **A** to **A**, etc.....

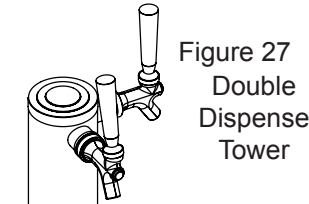

Figure 27
Double Dispense Tower

Figure 28



Hose clamps use for connections

A and **C**

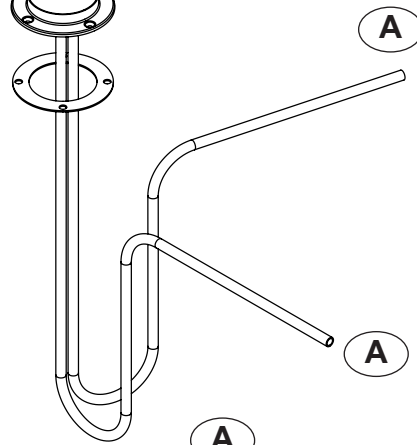

A
Keg Coupler

C

Figure 29

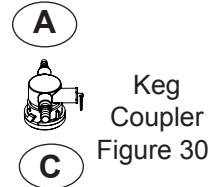

A
Keg Coupler
Figure 30

C

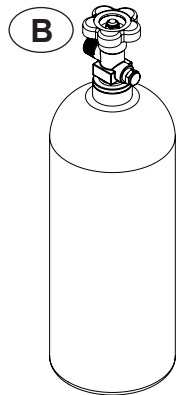
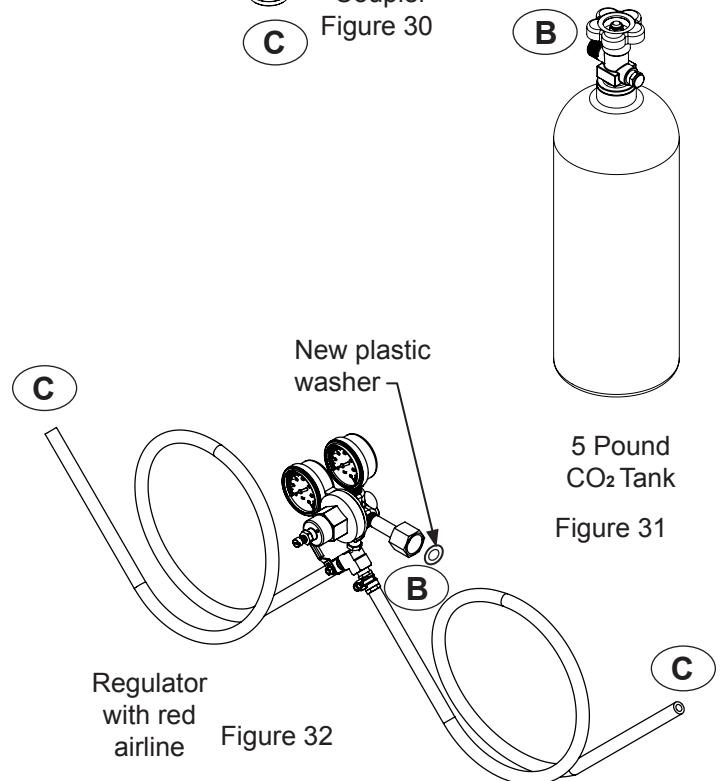

5 Pound CO₂ Tank

Figure 31

Regulator with red airline

Figure 32

USING YOUR BEER DISPENSER

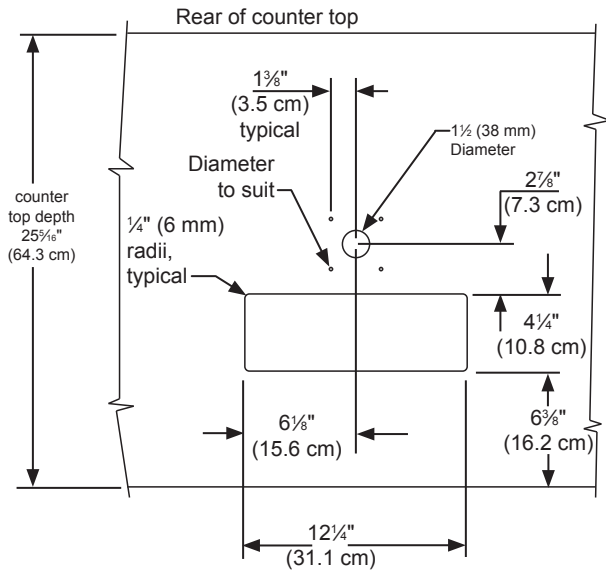

Figure 33



CAUTION

The cutout dimensions shown in Figure 33 are based on a 25 $\frac{5}{16}$ " (64.3 cm) deep counter top. Your counter top may be different than this and require other front to back dimensioning. Refer to the product dimensions on pages 8 and 9 when determining the required dimensions.

- If you are installing your keg refrigerator under a counter you will need to drill 5 holes in the counter top to mount the tower. The first hole is a 1 $\frac{1}{2}$ " diameter hole located at the center of the tower for the beer line, locate approximately 13 $\frac{1}{2}$ " (34.3 cm) from the front edge of the counter top (based on a counter top depth of 25 $\frac{5}{16}$ "). Next drill the 4 tower mounting holes per the dimensions in Figure 33. The hole diameter is dependent on the counter top material and if screw anchors are required. The screws supplied are in the literature pack and are a #10 x 1" type AB stainless steel screw. Mark and cut the rectangular cutout for the drain sump. After the holes are drilled and the keg refrigerator is in place under the counter top feed the beer line through the tower gasket, the 1 $\frac{1}{2}$ " hole in the counter top and the hole in the top of the keg refrigerator. Mount the tower to the counter top with the 4 screws provided. Place the counter top drain sump, from the literature pack, in the rectangular hole with the radius cutout to the rear around the tower and place the grate in the sump.
- Mount the regulator to the CO₂ tank (connection **B**) use the new plastic washer you received from the gas supply company. Note that the regulator has left hand threads and has to be turned counterclockwise to tighten. Tighten with the adjustable wrench or the 1 $\frac{1}{8}$ " open end wrench.
- Connect the red air line(s) from the regulator to the **large** air line fitting on the keg coupler with a **large** hose clamp (connection **C**).
- Connect the clear beer line from the tower to the **small** air line fitting on the keg coupler with a **small** hose clamp (connection **A**).

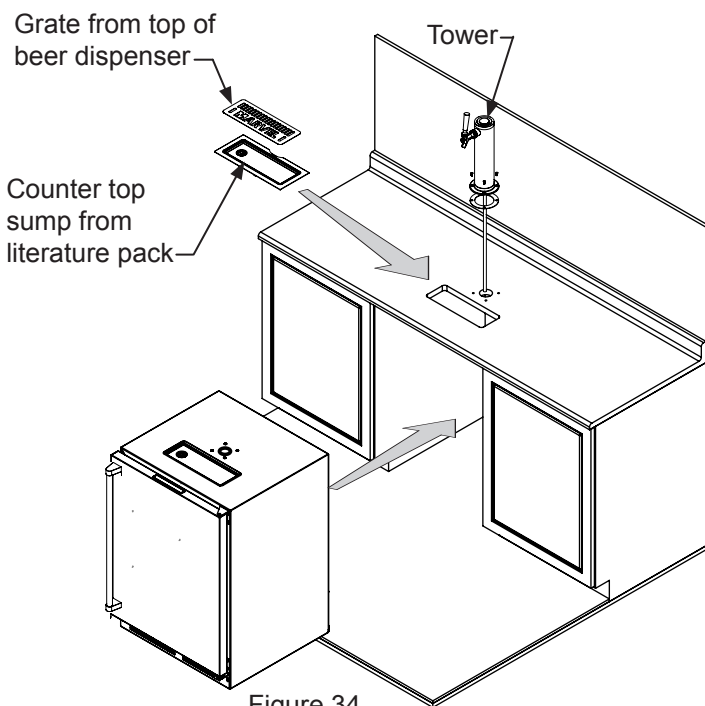

Figure 34

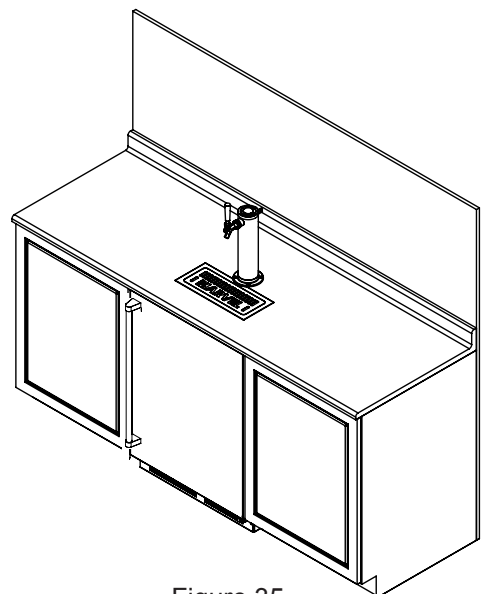
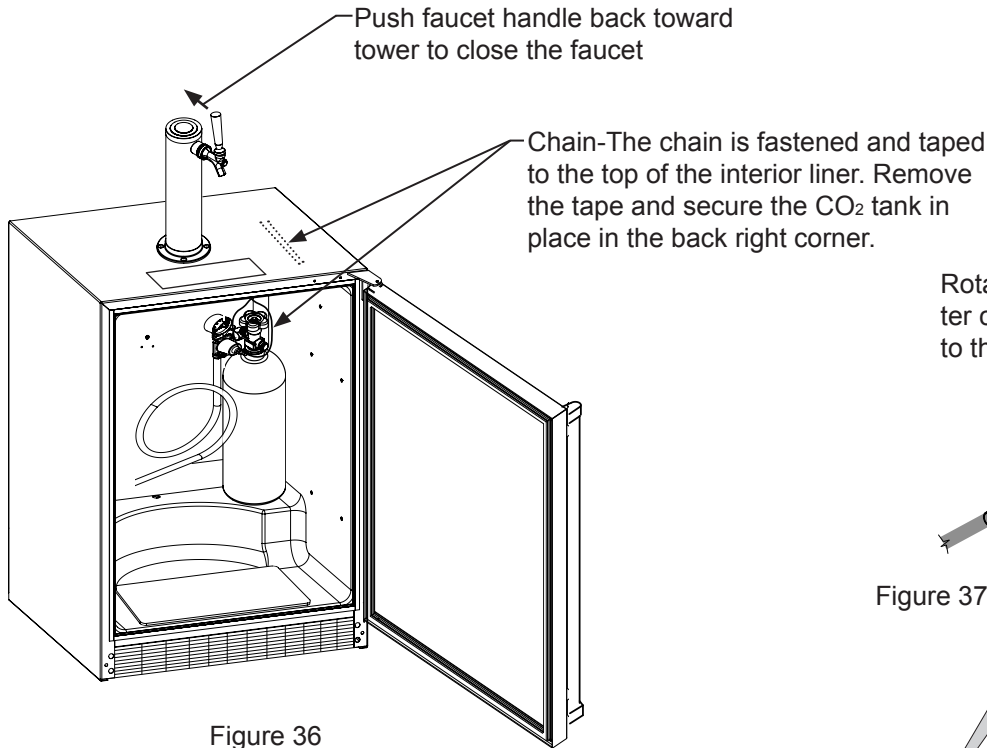

Figure 35

USING YOUR BEER DISPENSER

8. Locate the CO₂ tank in the corner of the refrigerator as shown in Figure 36 and secure with the chain. Close the faucet handle on the tower.
9. Hooking up the keg coupler to the keg: Verify the coupler is in the "OFF" position (see Figure 37a). Align the lugs on the keg with the corresponding openings on the keg coupler and turn clockwise until the coupler stops (about 90°). Push down and twist the top of the coupler clockwise to allow gas to enter the keg.



Rotate the top of the coupler counter clockwise to extend the coupler to the "OFF" position.

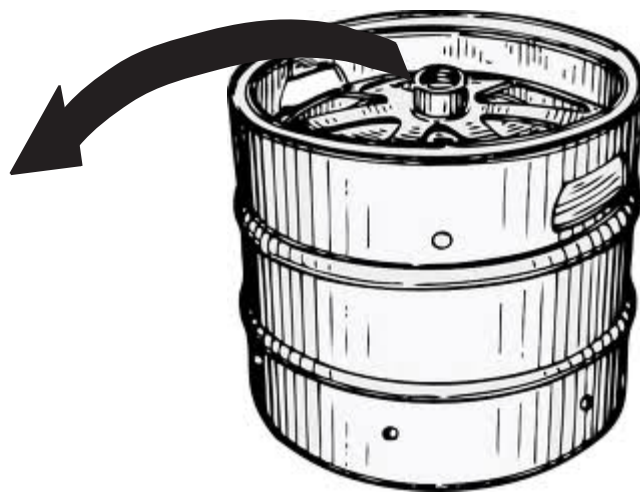
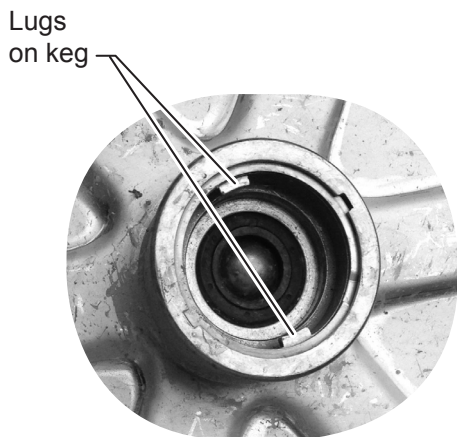
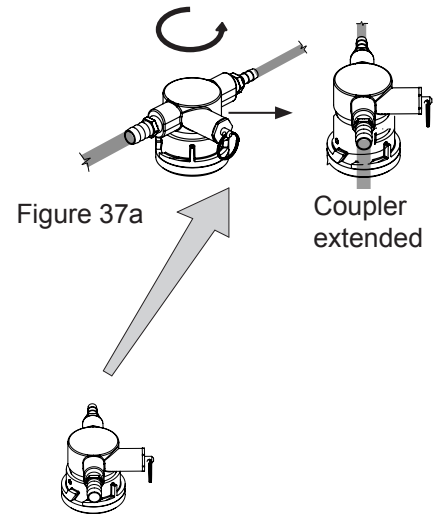

USING YOUR BEER DISPENSER

Optional CO₂ tank external mounting bracket:

The optional mounting bracket is designed to hold the 5# CO₂ cylinder that comes with the beer dispenser. Larger cylinders may be purchased from a third party and mounted externally. Use the hole port on the rear of the cabinet to run the CO₂ line to the keg.

Many options are available for mounting the CO₂ tank outside of the beer dispenser to gain additional cold storage space inside.

Secure the optional external mounting bracket on the back of the beer dispenser (this is ideal for mobile units) or mount within adjacent cabinetry (ideal for undercounter built-in units):

Mount the (4) screws (#10-32 x 3/4" flathead machine screws) provided with the bracket in the rear of the appliance, see Figure 38. Do not completely tighten. Place the keyhole slots in the flanges of the bracket over the four screws and tighten them to secure the bracket to the back of the cabinet. The bracket can also be fastened to adjacent cabinetry using the provided #10 x 3/4" wood screws. Mark the hole locations where required using a pencil and the slots in the mounting bracket. Drill appropriate pilot holes (depending on the material you are mounting to) and secure the bracket per the above instructions.

NOTE

Consider the length of the red air line when choosing a place for the CO₂ tank.

With the gauges mounted to the CO₂ tank place the tank in the mounting bracket.

Remove the foam plug from the hole port as shown in Figure 38, and feed the red CO₂ line through the rear wall and out the coil cover on the inside of the cabinet. Connect the red CO₂ line to the keg coupler.

Reseal the hole in the back of the cabinet with the foam plug. See Figure 39.

CAUTION

If the CO₂ tank is placed on the floor it must be secured in the upright position with a chain or other means to prevent it from being tipped over.

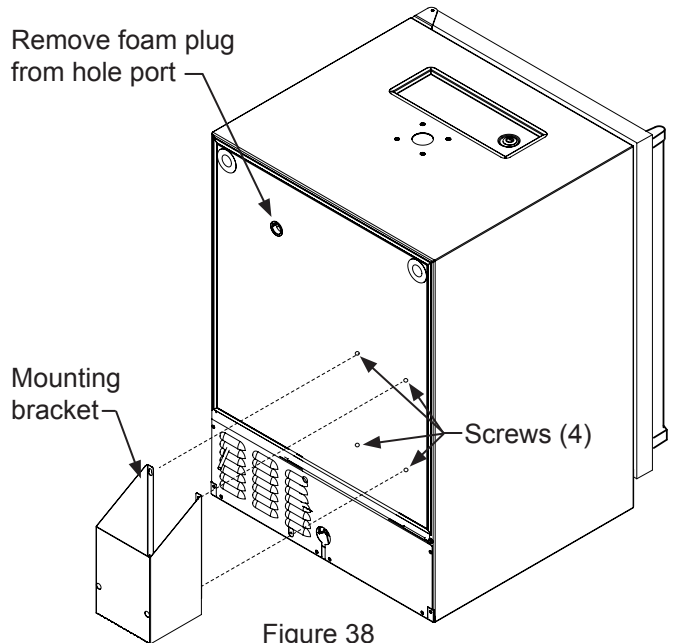

Reseal hole around tubing with the foam plug

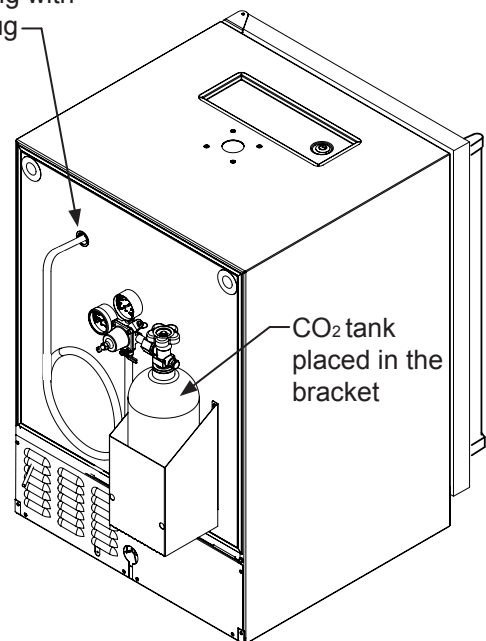

USING YOUR BEER DISPENSER

CO₂ Regulator (Single Dispense Tower)

Your beer dispenser comes equipped with a 5 pound CO₂ tank and a single gauge regulator. The gauge reads the pressure being supplied to the beer keg. Follow the procedure below to adjust the pressure to 12 - 14 psi (0.8 to 1 bar) for lager beer or 9 - 12 psi (0.6 to 0.8 bar) for ale's.

To adjust the pressure (Single Gauge):

1. Close the shutoff valve at the bottom of the regulator.
2. Be sure the faucet handle is closed on the tower (see Figure 36).
3. Loosen the lock nut by turning \curvearrowright counterclockwise using the $\frac{1}{2}$ " open end wrench until loose, this will allow adjustment of the pressure adjustment screw.
4. With the flat bladed screwdriver turn the adjustment screw \curvearrowright clockwise to increase the pressure or \curvearrowleft counterclockwise to decrease the pressure.
5. Open the shutoff valve on the bottom of the regulator. The gauge reading may drop but will return very quickly.
6. Pull the ring on the keg coupler to allow the gas to flow momentarily.
7. Make any fine adjustments if necessary with the adjustment screw.
8. Tighten the locknut with the $\frac{1}{2}$ " open end wrench by turning clockwise \curvearrowright .

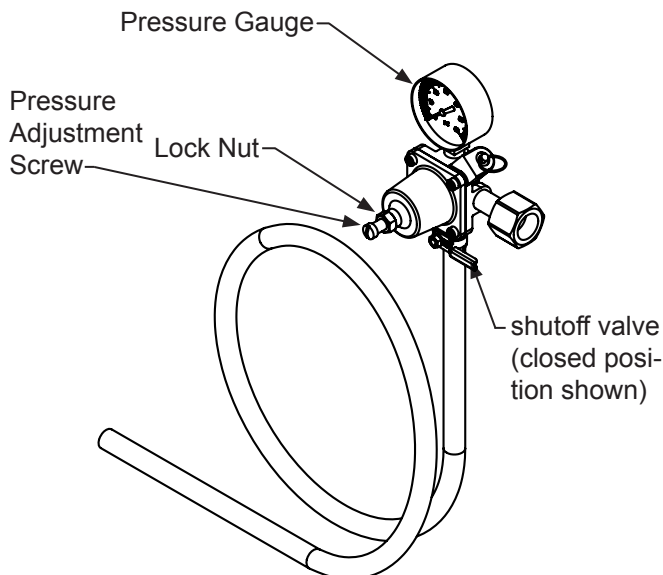
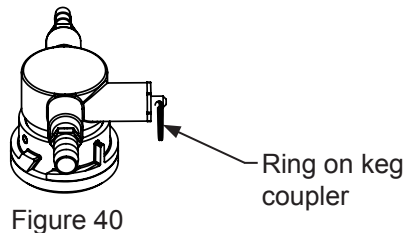

Figure 41 (Regulator for Single Dispense Tower)

CO₂ Regulator (Double Dispense Tower)

Your beer dispenser comes equipped with a 5 pound CO₂ tank and a dual gauge regulator. The lower gauge should be reading approximately 750 psi (52 bar) when the tank is properly filled and the tank is not in the refrigerator (at room temperature). The tank will read less when chilled. Use this lower gauge as an indicator of how much CO₂ you have left in the tank.

The upper gauge reads the pressure being supplied to the beer keg. Follow the procedure below to adjust the pressure to 12 - 14 psi (0.8 to 1 bar) for lager beer or 9 - 12 psi (0.6 to 0.8 bar) for ale's.

To adjust the pressure (Upper Gauge):

1. Close the shutoff valves at the bottom of the regulator.
2. Be sure the faucet handle is closed on the tower (see Figure 36).
3. Loosen the lock nut by turning \curvearrowright counterclockwise using the $\frac{1}{2}$ " open end wrench until loose, this will allow adjustment of the pressure adjustment screw.
4. With the flat bladed screwdriver turn the adjustment screw \curvearrowright clockwise to increase the pressure or \curvearrowleft counterclockwise to decrease the pressure.
5. Open the shutoff valve on the bottom of the regulator. The gauge reading may drop but will return very quickly.
6. Pull the ring on the keg coupler to allow the gas to flow momentarily.
7. Make any fine adjustments if necessary with the adjustment screw.
8. Tighten the locknut with the $\frac{1}{2}$ " open end wrench by turning clockwise \curvearrowright .

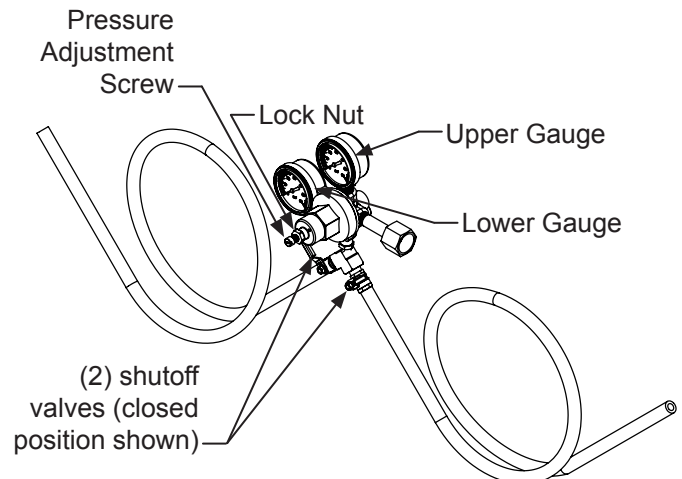

Figure 42 (Regulator for Double Dispense Tower)

USING YOUR BEER DISPENSER AND CARE AND CLEANING

Drain kit (All Models): The drain kit is shipped in place and ready to use. **To empty:** Pull drain hose out of bottle cap, remove bottle from unit, unscrew cap and discard waste and rinse bottle. Reinstall bottle in unit.

Cleaning the drain sump:

On a **free standing beer dispenser** remove the Marvel grate from in front of the tower, clean with soap and water and dry before reinstalling. Clean the sump area with soapy water and dry. (See figure 43).

On a **built in beer dispenser** remove the Marvel grate and counter top sump, clean with soap and water and dry before reinstalling. Clean the sump area with soapy water and dry. (See Figure 44).

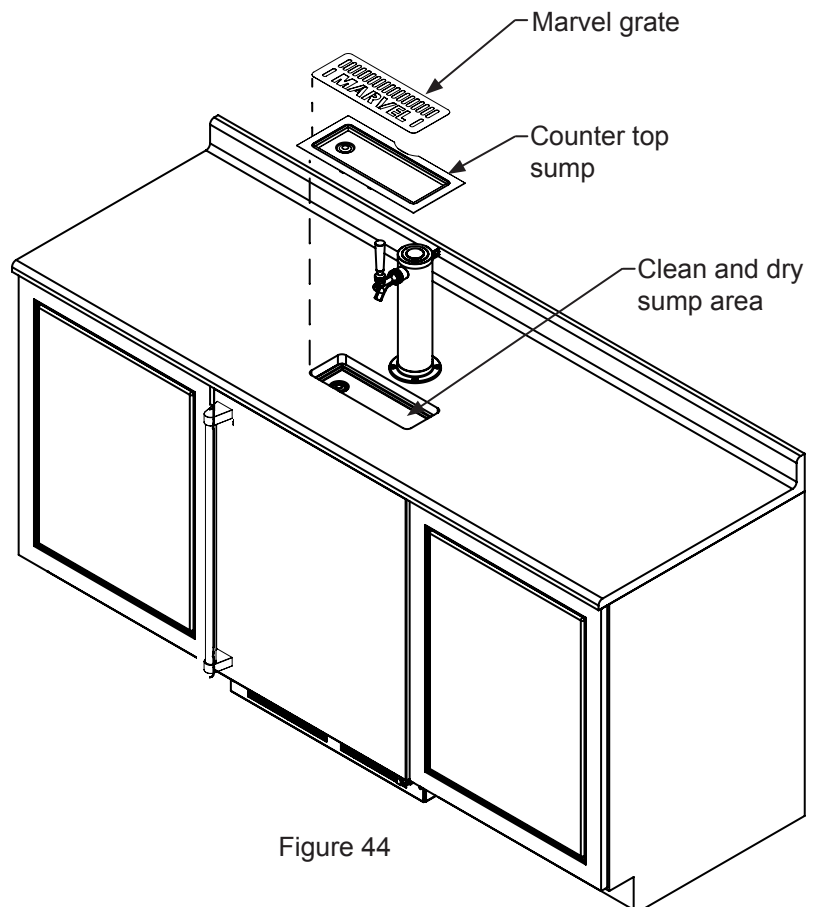
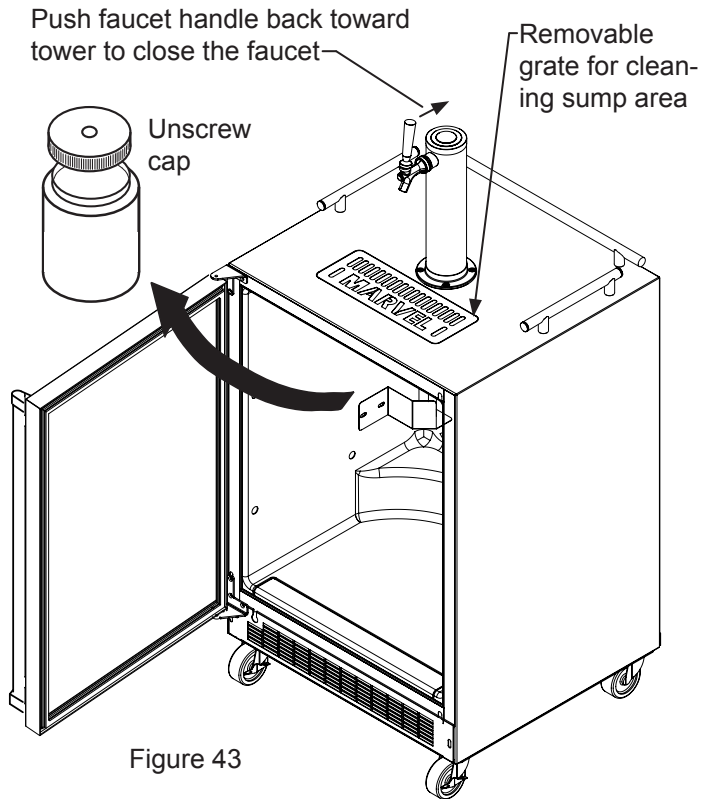

CARE AND CLEANING

Cleaning and Maintaining Dispensing System

The dispensing system needs to be cleaned between usage to prevent spoilage and/or foul taste in your beer.

Keg Coupler Cleaning

Remove the keg coupler from the keg if necessary. Close the gas valve(s) below the regulator, remove both the red gas line(s) and clear beer line(s) from the keg coupler(s) by removing the plastic hose clamps (See Figure 45). Soak and brush the keg coupler in hot water or a sanitizing solution. Rinse thoroughly with clean water. Dry all parts and reassemble.

Hose clamps can be released by a lateral movement to the head.

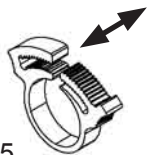

Figure 45

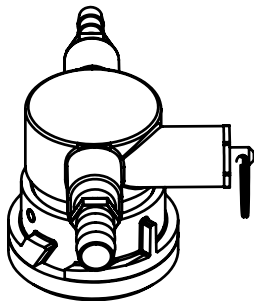
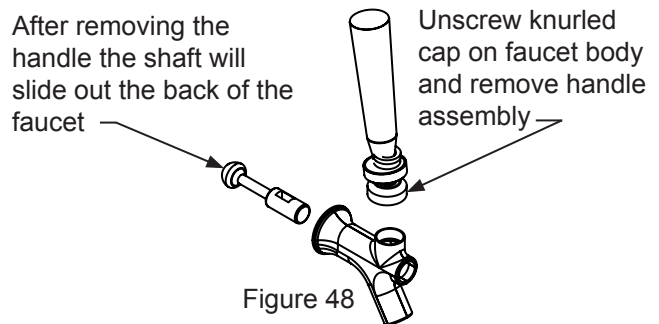
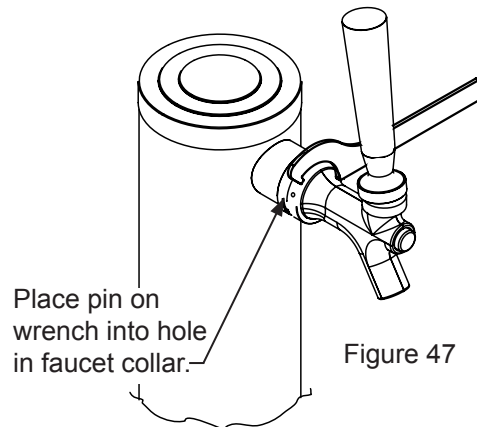

Figure 46

Faucet Cleaning

Turn off the gas supply with the shutoff valve(s) under the regulator (see Figure 41 or 42) and open the faucet to relieve the pressure. To remove the faucet from the tower use the spanner wrench provided. Place the pin on the wrench into the hole on the faucet collar and turn clockwise \curvearrowright to remove the faucet. (See Figure 47).

Remove the knurled cap from the faucet body just below the handle and pull the handle assembly from the faucet. This will allow the shaft to be removed from the back of the faucet, see Figure 48.



Soak all faucet parts in hot clear water or a solution of hot water and a sanitizing solution. Do not use soap. Rinse thoroughly with clean water.

Reassemble faucet, assemble faucet to tower (be sure faucet is in off position), and turn on gas valve.

CARE AND CLEANING

Tap Cleaning Kit

This is an optional item (part number 42242373) Kit includes everything to quickly clean tap. Includes cleaning solution, pump, mixing bottle, brush and wrench.

Cleaning the beer line (using tap cleaning kit 42242373):

With the faucet removed from the tower (see page 20) and the keg coupler removed from the keg (see page 20), place the end of the beer line in a pail or pan. Secure the pump to the tower with the coupler nut provided on the pump assembly. Pump a sanitizer / cleaner through the beer line until clean. Rinse the pump bottle with hot water, and using the pump, flush the beer line 2 or 3 times with clean hot water.

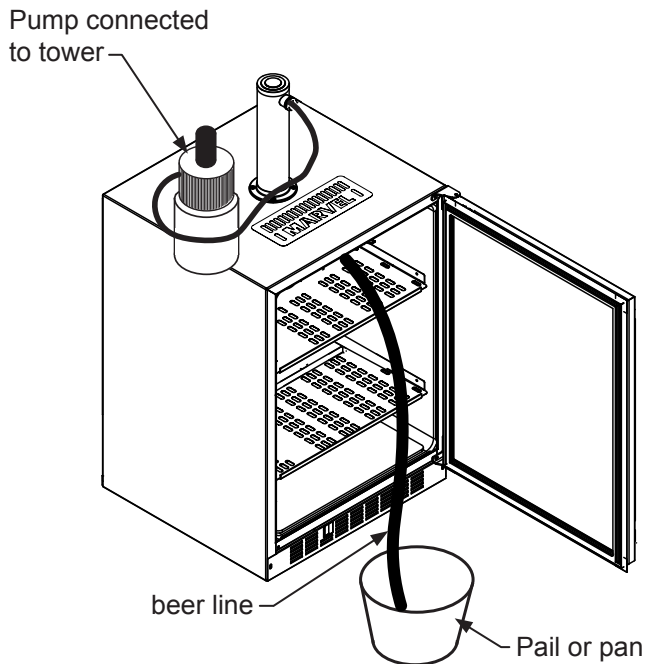

Figure 49

Front Grille

Be sure that nothing obstructs the required air flow openings in front of the cabinet. At least once or twice a year, brush or vacuum lint and dirt from the front grille area (see page 4).



SHOCK HAZARD: Disconnect electrical power from the appliance before cleaning with soap and water.

Cabinet

The stainless steel cabinet can be washed with either a mild soap and water and thoroughly rinsed with clear water. NEVER use abrasive scouring cleaners. Dry thoroughly with a terry towel.

Interior

Wash interior compartment with mild soap and water. Do NOT use an abrasive cleaner, solvent, polish cleaner or undiluted detergent.

Care of Appliance

1. Avoid leaning on the door, you may bend the door hinges or tip the appliance.
2. Exercise caution when sweeping, vacuuming or mopping near the front of the appliance. Damage to the grille can occur.
3. Periodically clean the interior of the appliance as needed.

In the Event of a Power Failure

If a power failure occurs, try to correct it as soon as possible. Minimize the number of door openings while the power is off so as not to adversely affect the appliance's temperature.

CARE AND CLEANING

Long term storage / winterization:

1. Time to Winterize, when the daily low ambient temperature is at or below 38F.

CAUTION

Operating of the unit at ambient temperatures below the recommended Winterization temperature will void your warranty.

2. Turn unit off, (see page 11).
3. Remove all contents.
4. If necessary, move the unit so you can gain access to the rear of the product.
5. Unplug the unit from the power outlet.
6. It is also recommended that the power to the outlet be turned-off if the circuit is not required for other items during the Winter season.
7. Shut-off CO2 tank valve.
8. Drain beer line(s)
 - a. Remove Sankey tap (keg coupler), (see page 20).
 - b. Remove faucet on tower, (see page 20).
 - c. Beer lines will gravity drain.
 - d. Clean beer line tubing, (see page 21).
9. Disassemble faucet and clean, (see page 20).
10. Soak and clean Sankey Low-Boy tap, (see page 20).
11. When cleaning unit pay particular attention to any cracks and crevices that may have accumulated dirt and debris.
12. Remove the front toe-grille, (see Figures 50 and 51), and use a brush and vacuum to clean dirt and debris from beneath the unit.
13. Thoroughly clean the toe-grille and re-install on the unit.
14. Remove the rear access cover, (see Figure 52), and use a brush and vacuum to clean dirt and debris from the machine compartment.
 - If the plastic defrost drain pan located under the compressor contains water, use a sponge to remove as much water as possible
15. Thoroughly clean the rear access cover and re-install on the unit.
16. Wipe down all interior surfaces with anti-bacterial cleaner to be followed with clean rinse water to remove any residual chemicals which could cause staining. Do not use any abrasive cleaners or scouring pads.
 - Remove plastic floor protector and stainless steel lower edge guard to clean underneath.

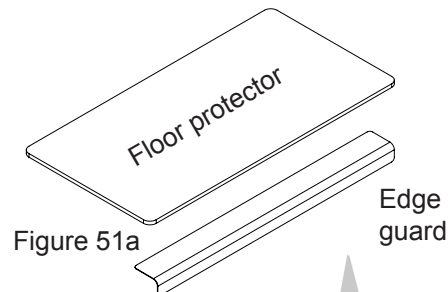
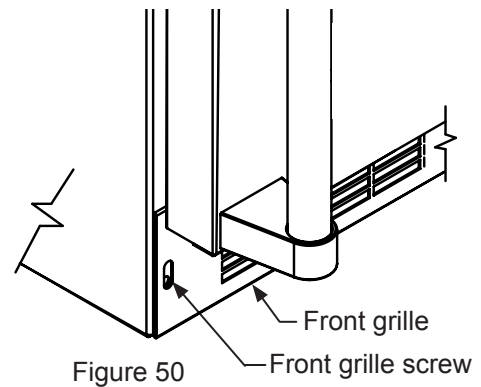

Remove floor protector and edge guard and clean

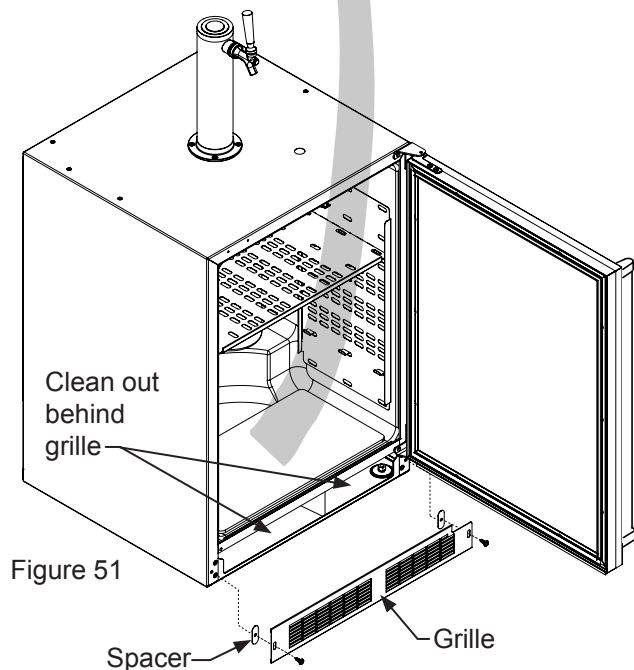

CARE AND CLEANING

17. Leave door open and allow to completely dry out before closing door.
18. Thoroughly clean the door gasket with anti-bacterial cleaner to be followed with clean rinse water to remove any residual chemicals.
19. Thoroughly clean the exterior with a cleaner approved for stainless steel . Do not use any abrasive cleaners or scouring pads.
20. Any mounting hardware / fasteners that are showing signs of corrosion should be replaced.
21. Once the exterior has been thoroughly cleaned, you may want to apply a coating of car wax to help protect against spotting from moisture, dirt, and debris that may accumulate on the surfaces during the Winterization period.
22. Do not place a cover on the unit, as this can trap condensation.

After completion of the above, you may choose to store the unit indoors, although this is not required.

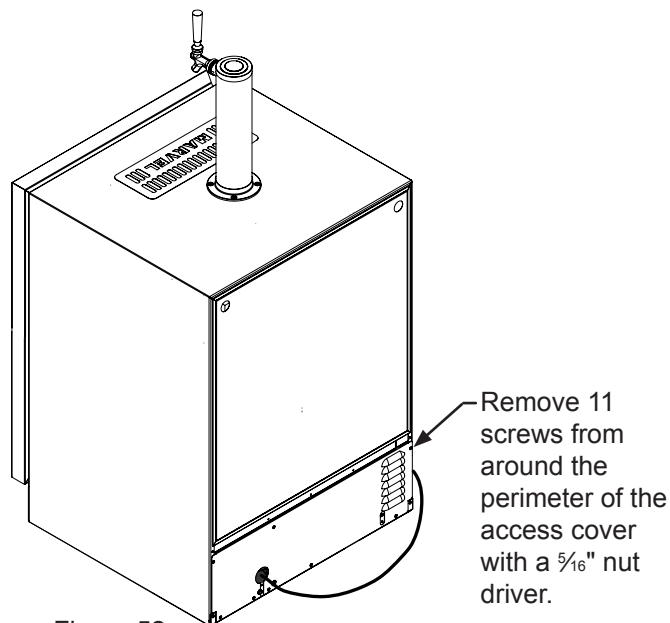

Figure 52

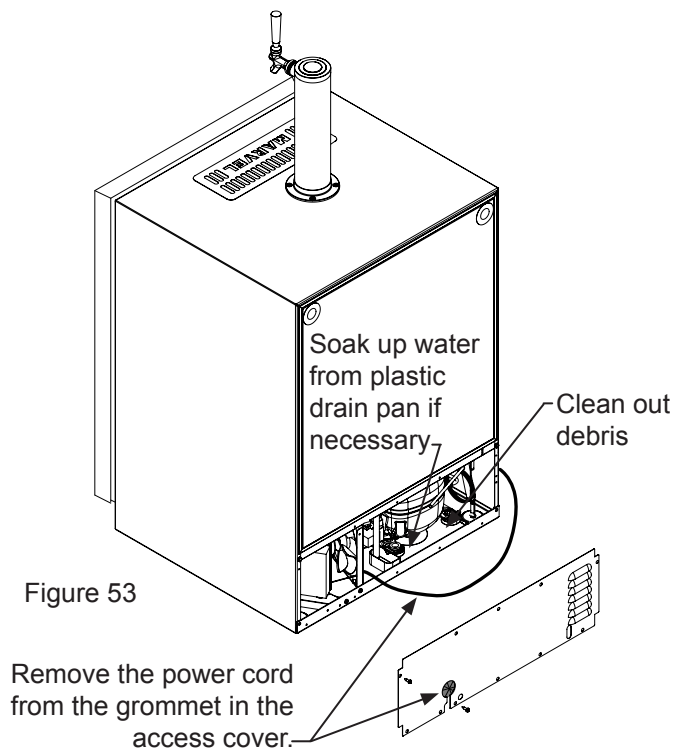

Figure 53

Start-Up After Long-Term Storage:

1. Connect the unit to electrical power.
2. If stored outside, it is recommended that the unit again be thoroughly inspected per the storage instructions above to address any dirt or debris from the weather and/or animals/insects.
3. Turn unit on and confirm your desired control settings.
4. Allow 24-hrs for the unit to stabilize before loading contents.

STAINLESS STEEL MAINTENANCE

Background

Stainless steel does not stain, corrode, or rust as easily as ordinary steel, but it is not stain or corrosion proof. Stainless steels can discolor or corrode if not maintained properly.

Stainless steels differ from ordinary carbon steels by the amount of chromium present. It is this chromium that provides an invisible protective film on the surface called chrome-oxide. This protective chrome-oxide film on the surface can be damaged or contaminated, which may result in discoloration, staining, or corrosion of the base metal.

Care & Cleaning

Routine cleaning of the stainless steel surfaces will serve to greatly extend the life of your product by removing contaminants. This is especially important in coastal areas which can expose the stainless to severe contaminants such as halide salts, (sodium chloride).

It is strongly recommended to periodically inspect and thoroughly clean crevices, weld points, under gaskets, rivets, bolt heads, and any locations where small amounts of liquid could collect, become stagnant, and concentrate contaminants. Additionally, any mounting hardware that is showing signs of corrosion should be replaced.

Frequency of cleaning will depend upon the installation location, environmental, and usage conditions.

Choosing a Cleaning Product

The choice of a proper cleaning product is ultimately that of the consumer, and there are many products from which to choose. Depending upon the type of cleaning and the degree of contamination, some products are better than others.

Typically the most effective and efficient means for routine cleaning of most stainless steel products is to give the surfaces a brisk rubbing with a soft cloth soaked in warm water and a gentle detergent, or mild mixture of ammonia. Rubbing should, to the extent possible, follow the polish lines of the steel, and always insure thorough rinsing after cleaning.

Although some products are called "stainless steel cleaners," some may contain abrasives which could scratch the surface, (compromising the protective chrome-oxide film), and some many contain chlorine bleach which will dull, tarnish or discolor the surface if not completely removed.

After the stainless surfaces have been thoroughly cleaned, a good quality car wax may be applied to help maintain the finish.

Note: Stainless steel products should never be installed, or

stored in close proximity to chlorine chemicals.

Whichever cleaning product you chose, it should be used in strict accordance with the instructions of the cleaner manufacturer.

DOOR ALIGNMENT AND ENERGY SAVING TIPS

Door alignment:

The door should be parallel to the sides and top of the appliance. If alignment is necessary the door may be adjusted by loosening the 2 screws which secure the door adjustment bracket on the bottom of the door (see Figure 54a) and adjusting the door side to side. Use a $\frac{5}{32}$ " allen wrench for this procedure. (See Figure 54 below). When finished aligning the door, tighten the screws securely.

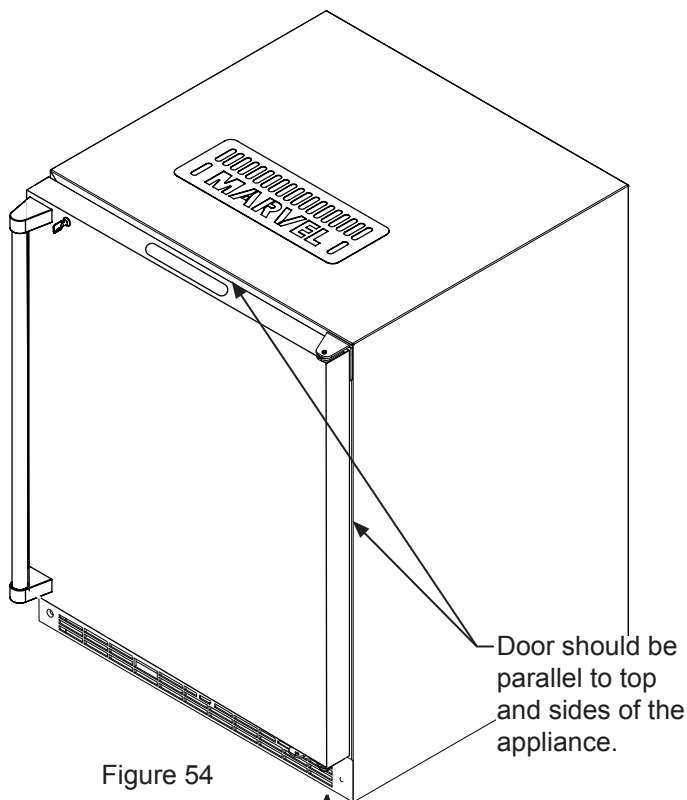

Figure 54

The following suggestions will minimize the cost of operating your refrigeration appliance.

1. Do not install your appliance next to a hot appliance (cooker, dishwasher, etc.), heating air duct, or other heat sources.
2. Install product out of direct sunlight.
3. Ensure the front grille vents at front of appliance beneath door are not obstructed and kept clean to allow ventilation for the refrigeration system to expel heat.
4. Plug your appliance into a dedicated power circuit. (Not shared with other appliances).
5. When initially loading your new product, or whenever large quantities of warm contents are placed within refrigerated storage compartment, minimize door openings for the next 12 hours to allow contents to pull down to compartment set temperature.
6. Maintaining a relatively full storage compartment will require less appliance run time than an empty compartment.
7. Ensure door closing is not obstructed by contents stored in your appliance.
8. Allow hot items to reach room temperature before placing in product.
9. Minimize door openings and duration of door openings.
10. Use the warmest temperature control set temperature that meets your personal preference and provides the proper storage for your stored contents.
11. When on vacation or away from home for extended periods, set the appliance to warmest acceptable temperature for the stored contents.
12. Set the control to the "off" position if cleaning the appliance requires the door to be open for an extended period of time.

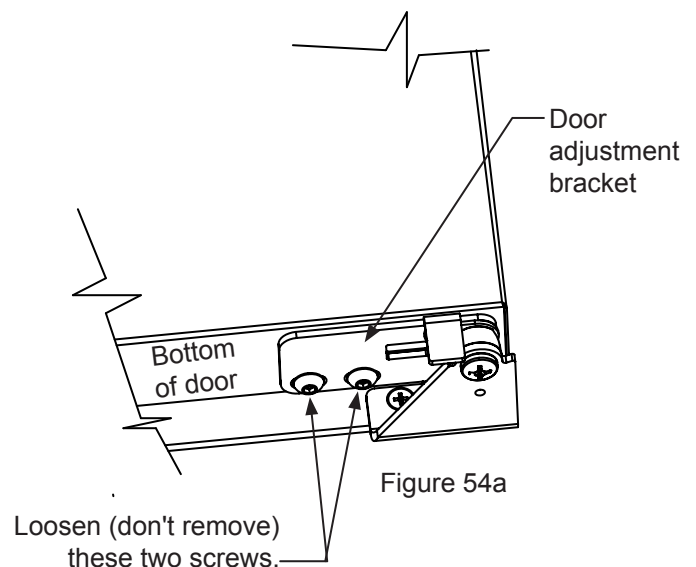

Figure 54a

TROUBLESHOOTING AND OBTAINING SERVICE

Before You Call for Service

If the appliance appears to be malfunctioning, read through this manual first. If the problem persists, check the troubleshooting guide below. Locate the problem in the guide and refer to the cause and its remedy before calling for service. The problem may be something very simple that can be solved without a service call. However, it may be required to contact your dealer or a qualified service technician.

If Service is Required:

- If the product is within the first year warranty period please contact your dealer or call AGA MARVEL Customer Service at 800.223.3900 for directions on how to obtain warranty coverage in your area.
- In all correspondence regarding service, be sure to give the service number, serial number, and proof of purchase.

- If the product is outside the first year warranty period, AGA MARVEL Customer Service can provide recommendations of service centers in your area. A listing of authorized service centers is also available at www.agamarvel.com under the service and support section.
- Try to have information or description of nature of the problem, how long the appliance has been running, the room temperature, and any additional information that may be helpful in quickly solving the problem.
- Table "C" is provided for recording pertinent information regarding your product for future reference.

For Your Records	
Date of Purchase	
Dealer's name	
Dealer's Address	
Dealer's City	
Dealer's State	
Dealer's Zip Code	
Appliance Serial Number	
Appliance Service Number	
Date Warranty Card Sent (Must be within 10 days of purchase).	

Table C



WARNING

Electrocution Hazard

- Never attempt to repair or perform maintenance on the appliance until the main electrical power has been disconnected. Turning the appliance control "OFF" does not remove electrical power from the unit's wiring.
- Replace all parts and panels before operating.

Problem	Possible Cause	Remedy
Appliance not cold enough (See "Adjusting the temperature" on page 11)	• Control set too warm	<ul style="list-style-type: none"> • Adjust temperature colder. Allow 24 hours for temperature to stabilize. • Allow temperature to stabilize for at least 24 hours. • Airflow must not be obstructed to front grille. See "clearances" on page 4. • Check door alignment and/or replace door gasket.
	• Content temperature not stabilized.	
	• Excessive usage or prolonged door openings.	
	• Airflow to front grille blocked.	
Appliance too cold (See "Adjusting the Temperature" on page 11)	• Door gasket not sealing properly.	<ul style="list-style-type: none"> • Adjust temperature warmer. Allow 24 hours for temperature to stabilize. • Check door alignment and/or replace door gasket.
	• Control set too cold	
Noise or Vibration	• Appliance not level	<ul style="list-style-type: none"> • Level appliance, see "Leveling Legs" on page 4. • Contact a qualified service technician.
	• Fan hitting tube obstruction.	
Appliance will not run.	• Appliance turned off	<ul style="list-style-type: none"> • Turn appliance on. See "Starting your appliance" on page 11. • Plug in power cord. • Check house circuit.
	• Power cord not plugged in.	
	• No power at outlet.	

HOUSEHOLD PRODUCT WARRANTY

Entire Product

Limited One Year Parts and Labor Warranty

AGA MARVEL warrants that it will supply all necessary parts and labor to repair or replace in the end user's home or office, any component which proves to be defective in material or workmanship, subject to the condition and exclusions stated below, for a period of one year from the date of purchase by the end user.

Additional Second Through Fifth Year

Limited Parts Only Warranty

During the four years following expiration of the one year limited warranty, AGA MARVEL will supply replacement parts for the hermetically sealed refrigeration system which consists of the compressor, condenser, drier, accumulator, bypass valve, connecting tubing and the evaporator that are proven to be defective due to workmanship or materials subject to the conditions and exclusions below.

The above warranties do not cover:

- Shipping costs of replacement parts or returned defective parts.
- Customer education or instructions on how to use the appliance.
- Any content loss due to product failure.
- Removal or installation of product.

Nor do the above warranties cover failure of this product or its components due to:

- Transportation or subsequent damages.
- Commercial use or use other than normal household or small office.
- Improper installation, misuse, abuse, accident or alteration, use of wiring not conforming to electrical codes, low or high voltages, failure to provide necessary maintenance, or other unreasonable use.

Parts or Service

Not Supplied or Designated by AGA MARVEL

The above warranties also do not apply if:

- The original bill of sale, deliver date, or serial number cannot be verified.
- Defective parts are not returned for inspection if so requested by AGA MARVEL.
- The refrigeration equipment is not in the possession of the original end use purchaser.

The warranties set forth herein are the only warranties extended by AGA MARVEL. Any implied warranties, including the implied warranty of merchantability, are limited to the duration of these express warranties. In no event shall AGA MARVEL be liable for any consequential or incidental damages or expenses resulting from breach of these or any other warranties, whether express or implied.

Some states do not allow the exclusion or limitation of consequential damages or a limitation on how long an implied warranty lasts, so the above exclusion or limitation may not apply to you. This warranty gives you specific legal rights and you may have other rights that may vary from state to state.

No person, firm, or corporation is authorized to make any other warranty or assume any other obligation for AGA MARVEL. These warranties apply only to products used in any of the fifty states of the United States and the District of Columbia.

To obtain performance of this warranty, report any defects to:

AGA MARVEL
1260 E. VanDeinse St.
Greenville MI 48838

Phone: 800.223.3900



www.agamarvel.com

AGA MARVEL

1260 E. VanDeinse St.
Greenville MI 48838

800.223.3900

41013896-EN Rev A
2/11/15

All specifications and product designs subject to change without notice. Such revisions do not entitle the buyer to corresponding changes, improvements, additions, replacements or compensation for previously purchased products.