



# TWINEAGLES

U S A

*Defining the Art of Outdoor Cooking*

## Twin Eagles Cooler Drawer

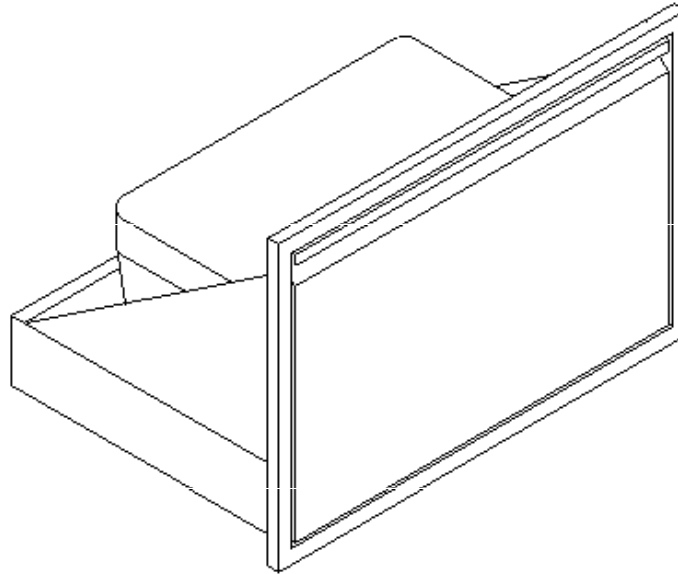

**TECD30-B**

### Features:

- ▼ Superior welding and finish
- ▼ Stainless steel welded construction
- ▼ Heavy duty, 100 lbs capacity, full extension and removable slides
- ▼ High-polished, non-protruding drawer handle
- ▼ One-piece 18 gauge front frame
- ▼ 48 quart Ice Chest INCLUDED (color may vary)
- ▼ Easy to install

### Specifications:

#### Overall Dimensions

Height	: 20.75"
Width	: 30.00"
Depth	: 20.75"
Ship Weight	: 48 lbs

#### Cutout Dimensions

Height	: 19.25"
Width	: 28.50"
Depth	: n/a

[www.twineaglesbbq.com](http://www.twineaglesbbq.com)

**Twin Eagles, Inc.**

13231 166<sup>th</sup> St. Cerritos, CA. 90703